



The Riding.com

YCF50E

20







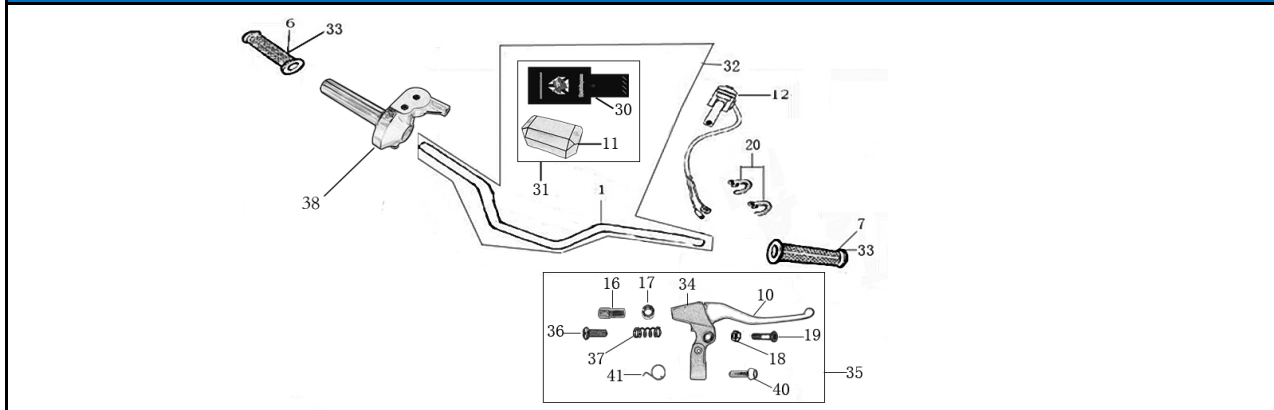

BIKE CODE FOR ORDERS:	19-50E-STD	BIKE DESCRIPTION NAME:	YCF 50
-----------------------	------------	------------------------	--------



Handle bar assembly



N°	Ref.	Description	Français	Picture	Qty/Bike
1	YC50-0101-01	Handle Bar YCF50 Chromelly L=570mm STEEL	Guidon YCF50 chromolly L=570mm		1
33	PPC010-GY	YCF set of grip GREY	Paire de poignée caoutchouc YCF GRISE		1
6	YC110-01-01-GY	YCF Right Grip GREY	poignée caoutchouc droite YCF GRISE		1
7	YC110-01-02-GY	YCF Left Grip GREY	poignée caoutchouc gauche YCF GRISE		1
35	YC50-01031	YCF50 Complete rear brake assy	Levier frein arriere complet YCF50 avec cocotte		1
10	YC50-0502-02	YCF50 Rear Brake lever (left side) L=128MM	Levier frein arriere (levier gauche) YCF50 L=128MM		1
34	YC50-0502-01	YCF50 Rear (left side) brake bracket YCF50	Cocotte frein arriere YCF50 (cote gauche)		1
	YC50-0116	Adjust bolt M10x15mm	vis cocotte frein M10x15mm		1
	YC50-0117	YCF50 Tight Nut M10	Ecrou cocotte frein YCF50 M10		1
	FB02-M5x18	YCF50 Stepped bolt M5X18	Vis YCF50 M5X18		1

	YC50-0136	Spring M4x15 to adjust rear brake lever	Ressort M4x15 pour réglage frein arriere		1
	YC50-1206	Spring for rear brake bracket M14x17	Ressort pour frein arriere M14x17		1
	GB6189-M5	Self-lock Nut M5	ecrou M5		1
	GB818-M4x15	Screw M4x15	Vis M4x15		1
	GB70.2-M6x16	Screw M6x16	Vis M6x16		1
11	YC50-0110-01	Bar pad for Handlebar YCF50 126x75x45mm	Mousse guidon pour Guidon YCF50 126x75x45mm		1
12	YC110-0105-03	YCF50 Kill Switch ON/OFF L=500MM	Coupe circuit on off YCF50 L=500MM		1
20	YC110-01-03-BK	Tape 150mm BLACK	colier maintien cable 150mm NOIR		2
20	YC110-01-03-WH	Tape 150mm WHITE	colier maintien cable 150mm BLANC		2
20	YC110-01-05-BK	Tape 350mm BLACK	colier maintien cable 350mm NOIR		5
30	YC50-0130-02	PVC for Bar Pad YCF50 89x243mm 2018 BLACK	PVC mousse guidon YCF50 89x243mm 2018 NOIR		1
31	YC110-0131-01	Complete Bar Pad for Handlebar without Bar L=126mm YCF50 2018 BLACK	Mousse guidon complete pour guidon Aluminium sans Barre YCF50 2018 L=126mm NOIR		1
32	YC110-0132-02	Handle Bar Chromelly (with bar pad and pvc) YCF50 2018	Guidon Chromolly complet avec mousse et pvc YCF50 2018		1
38	YC50-0138-01	Throttle Assy L=470mm	Poigne Acceleration YCF50E avec temoin batterie		1

Steering stem assembly

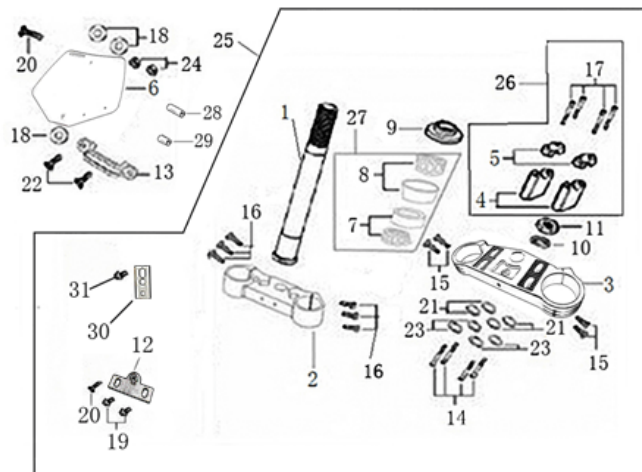





N°	Ref.	Description	Français	Picture	Qty/Bike
----	------	-------------	----------	---------	----------

1	YC50-0200-01	Steering stem 195 mm	tige colonne direction 195 mm		1
2	YC50-0202-05-GY	Lower triple clamp YCF50 135mm 2014 GREY	té fourche inferieur YCF50 135mm GRIS		1
3	YC50-0201-05-GY	Top Triple Clamp YCF50 135mm 2014 GREY	té fourche supérieur YCF50 135 mm GRIS		1
4	YC50-0203-04	YCF50 Lower Bar Mount CNC 35 mm BLACK	Pontet guidon inférieur YCF50 35mm NOIR		2
5	YC110-0202-04	Top Bar Mout CNC d22.2 mm/height 18mm START Type BLACK	pontet guidon supérieur d22.2 mm Type START NOIR		2
6	YC50-0212-02-WH	YCF Front Number Plate 50cc WHITE	plaque avant BLANC YCF 50cc		1
7	297-41/24	Lower Taper roller bearing 41/24	roulement inférieur 41/24		1
8	297-41/22.5	Top Taper roller bearing 41/22.5 R START 08	roulement supérieur 41/22.5		1
9	YC110-02-09	Top nut for steering d52	écrou crantellé colonne direction d52		1
10	YC110-02-10	Washer for steering stem nut d22.5xd36x0.7	joint colonne direction d22.5xd36x0.7		3
11	YC110-02-11	Nut for steering stem M22	écrou supérieur colnne direction M22		1
12	YC110-0213-02	Number plate bracket short L=60mm H=33mm	support plaque avant courte L=60mm H=33mm		1
13	YC110-02-14-WH	Break Line Retainer White	guide durite sur plaque avant Blanc		1
14	GB70-M8x20	Stud screw M8X20	vis M8X20 上压码		4
23	GB93-d8-W	Spring washer d8mm	rondelle d8mm		4
16	GB70-M8x25	Stud screw M8X25	vis M8X25		8
19	GB5787-M6x16-W	Hex. Bolt with Flanged Face M6X16	vis M6X16		2
20	GB9074.5-M6x16-W	Plus screw M6X16 (for bottom front No plate)	vis m6x16 bas plaque No avant		1
20	GB9074.5-M6x25-W	Plus screw M6X25 (for top front No plate)	vis m6x25 haute plaque No avant		1
21	GB97-d4-W	flat washer d4	rondelle d4		1

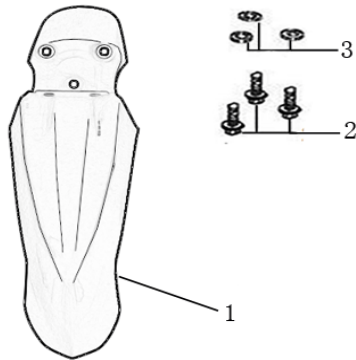
22	GB818-M4x10-W	Plus screw M4x10	vis M4x10		1
24	GB6170-M4-W	Nut M4	ecrou M4		2
25	YC50-0227-02-GY	Complete Triple Clamp YCF50 135mm 2014 GREY	Te Fourche Complet YCF50 135mm 2014 GRIS		1
26	YC50-0228	YCF50 Set of Bar mount not adjustable d22.2 mm/bottom 35mm(with GB70-M8x20 8EA+GB93-d8-W 4EA)	Jeu pontet guidon YCF50 non ajustable d 22.2 mm / pontet bas 35mm		1
27	KRDIRECTION41-2	set of bearing for steering 41/24、 41/22.5	kit rlt colonne direction 41/24、 41/22.5		1
28	FB13-9x10x17-W	Front Number plate spacer (Top) d 8.5x10x17	entretoise Plaque numero avant (Haut) d 8.5x10x17		1
29	FB13-9x10x6-W	Front Number plate spacer (Bottom) d 8.5x10x5.5	entretoise Plaque numero avant (Bas) d 8.5x10x5.5		1
30	YC110-0213-04	Number plate bracket long TOP BLACK	support plaque avant NOIR		1
31	GB5787-M6x16-W	Hex. Bolt M6X16	vis M6x16		1









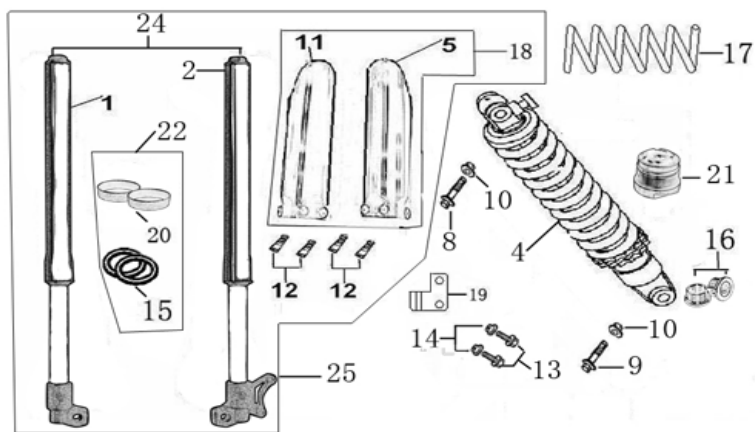





Front Fender



N°	Ref.	Description	Français	Picture	Qty/Block
1	YC50-031WH	Front Fender YCF50 WHITE	Gb avant YCF50 BLANC		1
2	GB5787-M6x20-W	Hex. Bolt with flanged M6X20	vis M6X20		3
3	GB96-d6-W	Washer d6xd18mm	Rondelle d6xd18mm		3
3	YC110-03-01	Rubber washer d6xd18x4mm	caoutchouc d6xd18x4mm		3

Front & Rear absorber





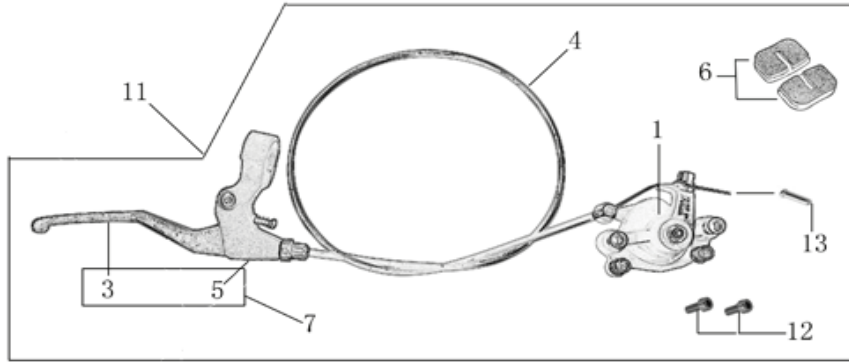

N°	Ref.	Description	Français	Picture	Qty/Blake
1	YC50-0401-04	Front right fork 530 mm (not adjustable) MAGNESIUM	tube fourche droit 530 mm MAGNESIUM		1
2	YC50-0402-04	Front left fork 530mm (not adjustable) MAGNESIUM	tube fourche gauche 530 mm MAGNESIUM		1
4	YC50-0404-03	YCF50 Shock absorber L=200mm 2014 YELLOW	Amortisseur YCF50 L=200mm 2014 JAUNE		1
16	YC50-0410-02	shock top spacer 50CC 2014 d10xd22x21.5mm	Silent Block haut amortisseur 50CC 2014 d10xd22x21.5mm		1
16	YC50-0411-03	shock bottom spacer 50CC 2014 d10xd20xd26x11mm	Silent Block bas amortisseur YCF50 d10xd20xd26x11mm		2
5	YC50-04-01-WH	Left front fork protection YCF50 L=530mm WHITE	Protection fourche gauche YCF50 L=530mm BLANC		1
	YC50-0421-WH	YCF50 Brake Cable clip WHITE	Capot passe durite frein avant YCF50 BLANC		1
	GB70-M4x15	Hex. Bolt M4x15	vis M4x15		2
	GB6170-M4	Nut M4	ecrou M4		2
8	GB5787-M10x45	Hex.bolt for shock absorber M10x45	Vis amortisseur M10x45		2
10	GB6187-M10-W	Self-locking Nut M10	Ecrou vis amortisseur M10		2
11	YC50-04-02-WH	Right front fork protection YCF50 L=530mm WHITE	Protection fourche droite YCF50 L=530mm BLANC		1
12	GB70.2-M5x12	Plus screw M5x12	vis M5x12		4
	GB97-d5-W	Flat washer d.5	rondelle d.5		4
18	YC50-0418WH	YCF50 set of fork protection WHITE	Jeu protection fourche YCF50 BLANC		1
24	YC50-0400-03	YCF50 Pair of fork 530mm d35 (not adjustable) MAGNESIUM	Jeu de fourche YCF50 530mm d35 MAGNESIUM		1

Front Brake Assy





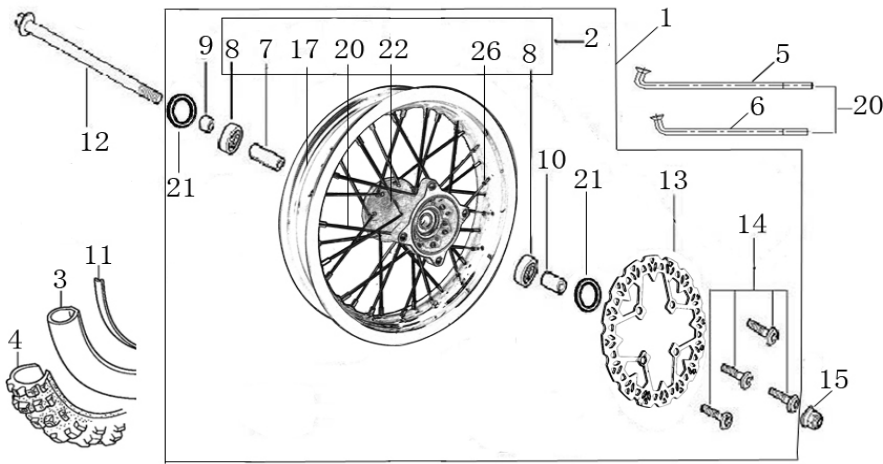

N°	Ref.	Description	Français	Picture	Qty/Bi ke
1	YC50-0502	YCF50 Front Brake caliper	Etrier frein avant YCF50		1
4	YC50-0501-03	YCF 50 Front brake cable 730mm.(with YC50-0513 1EA)	cable frein avant YCF50 730mm		1
	YC50-0501	YCF50 Complete front brake assy	Levier frein avant complet avec cocotte YCF50		1
3	YC50-0501-02	Front Brake lever (right side) L=143MM	levier frein pour (levier droit) L=143MM		1
	YC50-0515	Spring for front brake bracket M14x17	Ressort pour frein avant M14x17		1
5	YC50-0501-01	YCF50 Rear (right side) brake bracket 2012	Cocotte frein arriere YCF50 (cote droit) 2012		1
	YC50-0116	Adjust bolt M10x15mm	vis cocotte frein M10x15mm		1
	YC50-0117	YCF50 Tight Nut M10	Ecrou cocotte frein YCF50 M10		1
	FB02-M5x18	YCF50 Stepped bolt M5X18	Vis YCF50 M5X18		1
	YC50-0136	Spring M4x15 to adjust rear brake lever	Ressort M4x15 pour reglage frein arriere		1
	YC50-0515	Spring for front brake bracket M14x17	Ressort pour frein avant M14x17		1
	GB6189-M5	Self-lock Nut M5	ecrou M5		1
	GB818-M4x15	Screw M4x15	Vis M4x15		1
	GB70.2-M6x16	Screw M6x16	Vis M6x16		1
6	YC50-0506	YCF50 Front / Rear Brake pads	Jeu plaquette avant / arriere YCF50		2

11	YC50-0511	YCF50 front brake assy L=730mm	kit frein avant YCF50 L=730mm		1
	YC50-0513	Brake cable caps 50CC	Embout Cables frein 50CC		1
12	GB70-M6x25	Stud screw M6x25	vis M6x25		2
	GB97-d6-W	Washer d6	Rondelle d6		2
	GB93-d6-W	Standard spring washer d6	rondelle d6		2

Front Wheel Assy



N°	Ref.	Description	Français	Picture	Qty/Blake
1	YC50-0601-04	YCF50 Front wheel complete STEEL10",with brake& hardware. Casting hub . But without tire	roue avant complète 10' YCF50 moyeux injectée cerceau acier avec disque sans pneu ni chambre ni fond jante		1
2	YC50-0602-01	STEEL front wheel 10' without disk	roue avant ACIER sans disque 10'		1
17	YC50-0617-01	STEEL Rim for Front wheel 1.4x10'	cerceau roue av 1,4x10' ACIER		1
11	YC110-11-02	Tire lining for 10'	fond jante av 10'		1
21	YC50-0610	OIL SEAL d22xd32x5	joint spy roue d22xd32x5		2
8	6201RS	YCF50 Ball bearing 6201RS d32xd12x10mm	Roulement roue 6201RS d32xd12x10mm YCF50		2
22	YC50-0622-02	YCF50 Front hub injected with washer	Moyeux avant injectée avec joint spy YCF50		1

3	CHAMBRE10-2.5	Tube for front tire 2.50-10' GL	chambre air 2.50-10' GL		1
	FB6170-M8-Cr	Tire valve nut M8	Ecrou M8		1
4	250/10	Tire 2.50-10' GUANGLI	pneu 250-10' GUANGLI		1
	JR10-10.6	set of spoke 10' 50cc 2012(104mmx8+106mmx16+111mmx8)	JEUX RAYON AV 10' 50cc 2012 (104mmx8+106mmx16+111mmx8)		
7	YC50-0607-01	Front axle bushing 50A d14xd20x46	entretoise centrale roue avant 50A d14xd20x46		1
5	YC50-0605	outer spoke for 10wheel, 106 mm	Rayon extérieur 106 mm pour roue AV 10'		16
6	YC50-0622	inside spoke for 10wheel, 104mm	Rayon interieur 104 mm pour roue AV 10'		8
	S11110K	inside spoke for 10wheel, 111mm	Rayon interieur 111 mm pour roue AV 10'		8
9	YC50-06-052	YCF50 Right wheel spacer d12xd22x23	entretoise roue avant droite d12xd22x23 YCF50		1
10	YC50-06-051	Left wheel spacer d12xd22x26	entretoise roue avant gauche d12xd22x26		1
12	YC50-06-01	YCF50 Front Axle 170 mm with Self-locking nut d12	Axe de roue avant d12 L=170MM YCF50		1
15	GB6187-M12xP-W	Self-locking nut M12	écrou roue avant M12		1
13	YC50-0513-01	Front disk d160 mm 2016 换图	disque frein avant d160mm 2016 换图		1
14	GB70.2-M6x16	Socket head cap screw M6X16	vis disque frein M6X16		4

Fuel Tank

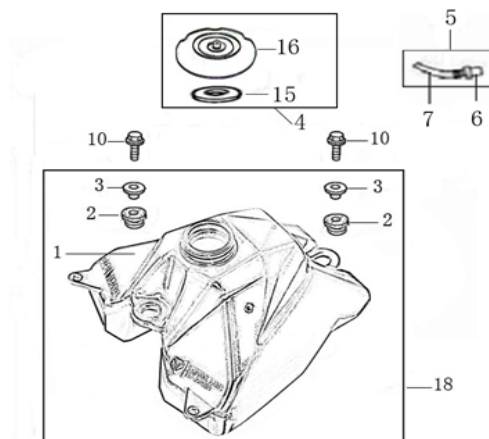







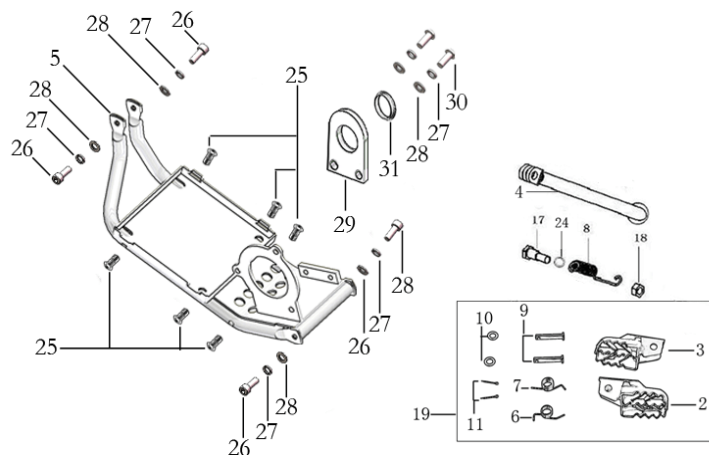













N°	Ref.	Description	Français	Picture	Qty/Block
----	------	-------------	----------	---------	-----------



1	YC50-07012	YCF50 Fuel tank with hole	Reservoir YCF 50cc avec trou		1
2	YC110-07-01	Cushion for fuel tank	caoutchouc pour reservoir		2
3	YC110-07-02	Washer for fuel tank d12xd30x11mm	entretoise pour reservoir d12xd30x11mm		2
5	YC125-0704-BK	Fuel tank valve BLACK	Valve prise air NOIR		1
6	YC110-0704-BK	Cap of Fuel tank valve BLACK	Capuchon Valve prise air NOIR		1
7	YC110-0705-BK	Fuel tank valve Hose L=40mm BLACK	Durite caoutchouc Vale prise air L=40mm NOIRE		1
10	GB5787-M8x25-B	Hex. Bolt with flanged M8X25 BLACK	vis M8X25 NOIR		2
16	YC110-0702-01	YCF Tank cap plastic 2013	Bouchon reservoir plastique YCF 2013		1
	YC110-0724-01	PLASTIC support for regulator	Support Regulateur poignee Acceleration		1
	YC110-0725-01	Regulator	Regulateur poignee Acceleration		1
18	YC50-0718	YCF50E Complete fuel tank WITH HOLES(with YC110-07-01 2EA+YC110-07-02 2EA)	Reservoir complet YCF50E 2013 AVEC TROU		1

Foot Peg assy



N°	Ref.	Description	Français	Picture	Qty/Block
2	YC50-0902	YCF50 right foot pegs steel L=65mm GREY	Repose pied droit acier YCF50 L=65mm GRIS		1
3	YC50-0901	YCF50 left foot pegs steel L=65mm GREY	Repose pied gauche acier YCF50 L=65mm GRIS		1

4	YC110-198	Kick stand 225mm	bequille 225mm		1
5	YC50-204-02	Motor skid plate 50E 2016	Sabot moteur - Batterie YCF50E Aluminium		1
25	GB6100-M6-CW	nut M6x25mm	Vis M6x25mm		6
26	GB70-M8x20	Hex. Bolt with flanger M8x20	vis boucle arriere M8x20		4
27	GB93-d8-W	Standard spring washer d8	rondelle d8		4
28	GB97-d8-W	flat washer d8	rondelle d8		4
29	YC50-1632-01	Fixed Motor right 50E 2016	Fixation Moteur cote droit		1
30	GB70.2-M8x20	screw M8x20	vis M8x20		2
27	GB93-d8-W	Standard spring washer d8	rondelle d8		2
28	GB97-d8-W	flat washer d8	rondelle d8		2
31	YC50-1633-01	Cushion for Motor right	Entretoise Maintient moteur Droit		1
6	YC110-09-01	Spring for right steel foot peg d1.5xd16.5x10mm	ressort repose pied droit acier d1.5xd16.5x10mm		1
7	YC110-09-02	Spring for left steel foot peg d1.5xd16.5x10mm	ressort repose pied gauche acier d1.5xd16.5x10mm		1
8	YC110-19-01	spring for kick stand d2.5xd15x105	ressort bequille d2.5xd15x105		1
9	GB882-d8x40-W	shaft pin for steel footpegs d8x40	axe repose pied acier d8x40		2
10	GB97-d8-W	flat washer d8x16x1	rondelle d8x16x1		2
11	GB91-d2x25-W	Cotter pin 2.0x25	goupille 2.0x25		2
17	FB02-M10x1.5x30I	Stepped screw M10X35 for kick stand	vis bequille M10X35		1
18	GB6170-M10-G	Hex. Nut M10	ecrou bequille M10		1

19	YC50-0902/03	Steel set of foot pegs 50cc Grey	jeu repose pied acier 50cc Grise		1
24	GB93-d10-W	Standard spring washer d10	rondelle d10		1

Swing Arm assy

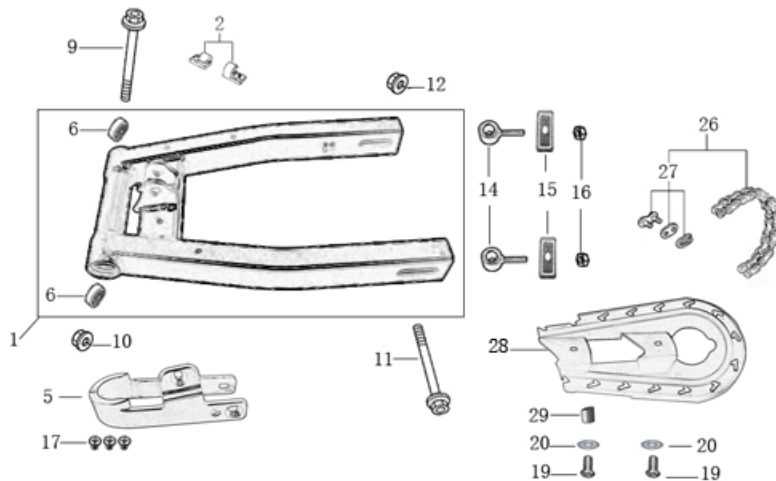







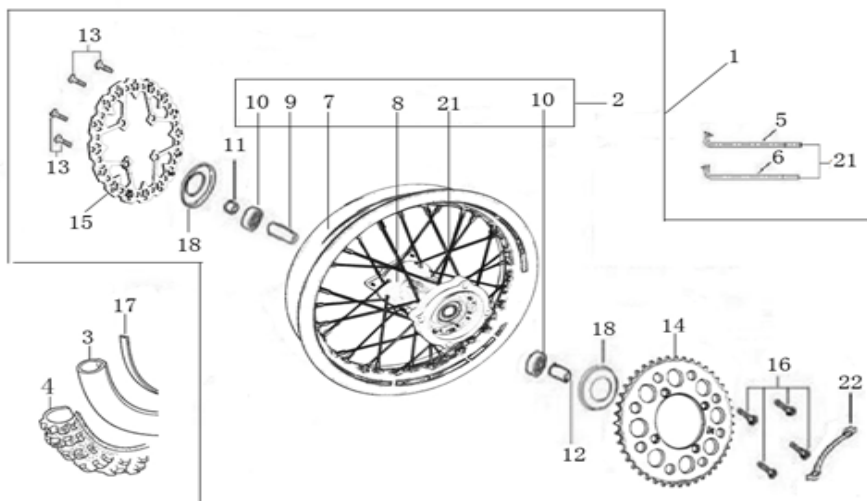





N°	Ref.	Description	Français	Picture	Qty/Block
1	YC50-10014	YCF50 Mono swing arm BLACK	bras oscillant mono YCF50 NOIR		1
2	YC110-10-014-BK	Rear brake clip for BLACK	attache durite frein arriere NOIR		1
17	GB819-M6x16-W	Plus screw M6X16	vis m6x16		5
	GB6100-M6-CW	nut M6x25mm	Vis M6x25mm		5
5	YC50-10-01	YCF Chain slider 50cc	patin chaine YCF 50cc		1
6	6001/28-12-08	Swing arm bearing d28xd12x8mm	roulement bras oscillant d28xd12x8mm		2
9	YC50-1009	Swing arm shaft with self lock nut d12x190mm	axe bras oscillant d12x190mm		1
10	GB6187-M12-W	Self locking nut M12	ecrou bras oscillant M12		2
11	YC50-11-02	YCF50 Rear wheel axle M12x215 with Self locking nut M12	axe roue arriere YCF50 L=215mm avec ecrou d12		1
16	YC50-1001-001	YCF50 Block axle	Tendeur chaine YCF50		2

16	YC50-1001-002	YCF50 Block axle fixing plate	Patte acier fixation tendeur chaine YCF50		2
	GB6189-M8-W	Cltch Self-lock Nut M8	ecrou M8		2
19	GB818-M6x16-W	Plus screw M6x16	vis M6x16		1
19	GB818-M6x25-W	Plus screw M6x25	vis M6x25		1
20	GB97-d6	Flat washer d6	rondelle d6		3
26	RS35-114T	Driving chain RS35-114	Chaine RS35-114 maillons		1
27	AR-35	Chain link H=13mm	Attache rapide chaine H=13mm		1
28	YC50-0600-02	YCF50 Chain box protection YCF50	Protection chaine plastique YCF50		

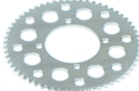
Rear Wheel Assy



N°	Ref.	Description	Français	Picture	Qty/Block
1	YC50-1101-06	Complete STEEL Rear wheel 1.40-10' Casting hub with disk 50E 2016	roue arriere complète Acier 1.40-10 moyeux injecte avec disque 50E 2016		1
2	YC50-1102-01	Complete STEEL Rear wheel 1.40x10' without disk	roue arriere complète ACIER 1.40x10' moyeux injecte sans disque		1
3	CHAMBRE10-2.5	Tube for Rear tire 2.50-10 GL	chambre air 2.50-10' GL		1
	FB6170-M8-Cr	Tire valve nut M8	Ecrou M8		1

4	250/10	YCF tyre 2.50/10' GUANGLI	pneu 2.50/10' YCF GUANGLI		1
5	YC50-0606	outer spoke for 10' wheel 111 mm	Rayon extérieur 111 mm pour roue AV 10'		16
6	YC50-0605	inside spoke for 10' wheel 106 mm	Rayon interieur 106 mm pour roue AV 10'		16
7	YC50-1117-01	STEEL Rim 1.40x10'	cerceau roue 1,40x10 ACIER		1
8	YC50-1122-02	YCF50 Rear wheel hub Casting with seal	Moyeux arrière YCF50 injecte avec joint spy		1
10	6201RS	Ball bearing 6201RS d32xd12x10mm	roulement roue 6201RS d32xd12x10mm		2
12	YC50-11-041	Axle spacer, dd22xd12x25mm (left/right)	entretoise roue arrière (droit/gauche) d22xd12x25mm		2
14	YC110-11-05/60	YCF Driven sprocket RS35 60T	couronne acier RS35 60T		1
22	YC110-11-03	Sprocket Locking piece	block couronne		2
16	GB5783-M8x20-W	Exterior Hex.Bolt M8X20	vis couronne m8x20		4
15	YC50-0513-01	YCF50 disk d160 mm 2016	disque YCF50 d160mm 2016 换图		1
13	GB70.2-M6x16	Socket head cap screw M6x16	vis de disque M6x16		4
17	YC110-11-02	Tire lining for 12	fond jante 12'		1
18	YC50-0610	OIL SEAL d22xd32x5	joint spy roue d22xd32x5		2
21	JR10-10.5	set of spoke 10' (106mmx16+111mmx16)	jeu rayon arrière 10' (106mmx16+111mmx16)		1

REAR BRAKE

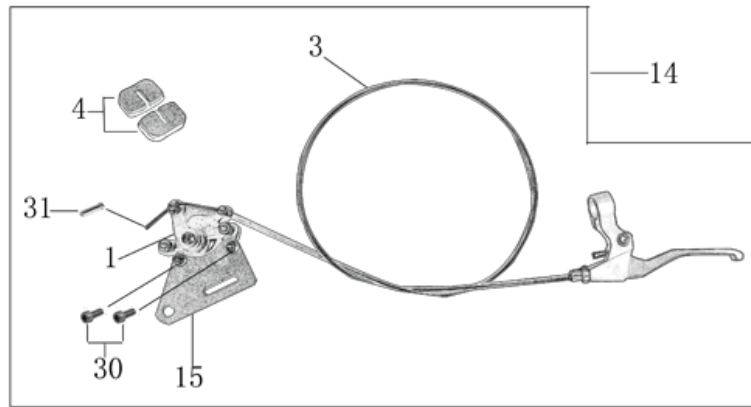

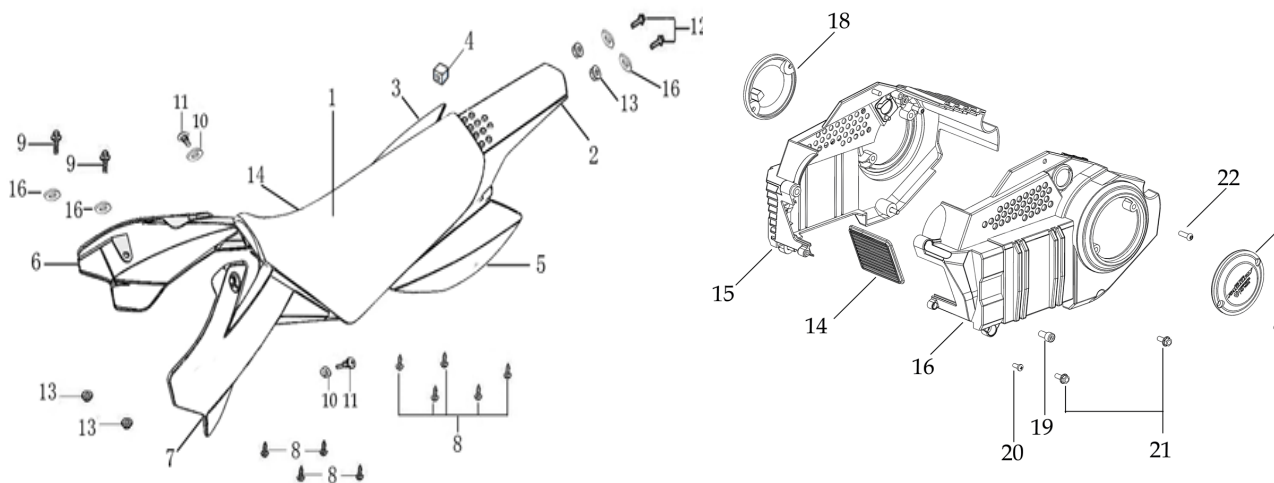

N°	Ref.	Description	Français	Picture	Qty/Bi ke
1	YC50-1201	YCF50 Rear Brake caliper	Etrier frein arriere YCF50		1
3	YC50-0502-03	YCF50 Rear brake steel line 1050mm A+B=120mm(with YC50-0513 1EA)	durite frein arriere YCF50 1050mm A+B=120mm		1
4	YC50-0506	Front / Rear Brake pads	jeu plaquette avant / arriere		2
14	YC50-1214	YCF50 Rear brake assy L=1050mm	Kit frein arriere YCF50 L=1050mm		1
	YC50-0513	Brake cable caps 50CC	Embout Cables frein 50CC		1
15	YC50-120101-02	Rear brake bracket T=3mm 2014	patte fixation étrier frein arriere T=3mm 2014		1
	FB13-7x10x4-W	bushing d7xd10x4mm	entretoise d7xd10x4mm		2
30	GB70-M6x12	Hex. Bolt M6x12	vis M6x12		2

Seat & Plastic kit







N°	Ref.	Description	Français	Picture	Qty/Bi ke
----	------	-------------	----------	---------	--------------



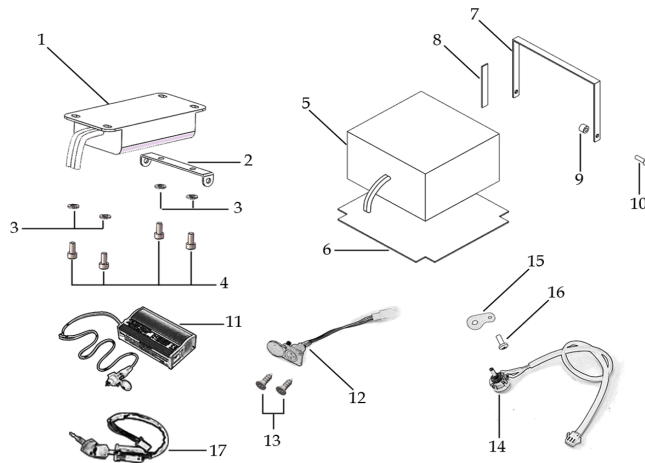







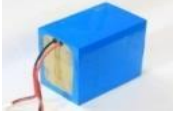





1	YC50-1401-05	YCF50 Seat assy L=405mm 2016	Selle YCF50 2016		1
2	YC50-14-012-WH	YCF50 Rear fender WHITE	Garde boue arrière YCF50 BLANC		1
3	YC50-14-022-WH	YCF right side plastic WHITE	Plaque latérale droite YCF BLANCHE		1
4	YC110-14-03	Cushion for right side plastic	caoutchouc plaque laterale droite		1
5	YC50-14-042-WH	YCF50 Left side plastic WHITE	Plaque latérale gauche YCF50 BLANCHE		1
6	YC50-14-05-BK	YCF Right shroud BLACK 50CC	ouie radiateur droite YCF 50CC NOIR		1
7	YC50-14-06-BK	YCF Left side shroud BLACK 50CC	ouie radiateur gauche YCF 50CC NOIR		1
8	GB845-ST4.8x16-G	Screw for plastic kit ST4.8x16	vis plastique ST4.8x16		9
9	GB5787-M6x25-W	hex. Bolt with flanged M6x25	vis M6x25		1
9	GB5787-M6x20-W	hex. Bolt with flanged M6x20	vis M6x20		1
16	YC110-03-01	Rubber washer d6xd18x4mm	joint caoutchouc d6xd18x4mm		2
16	GB96-d6	flat washer d6	rondelle d6		2
13	GB6177-M6-W	Hex. Flanged nut M6	écrou M6		2
11	FB5787-M5x12-W	hex. Bolt with flanged M5x12	vis M5x12		2
11	GB96-d5-W	flat washer d5xd12	rondelle d5xd12		2
10	YC110-02-13	Rubber washer d6xd14x3mm	joint caoutchouc d6xd14x3mm		2
12	GB5787-M6x20-B	hex. Bolt with flanged M6x20 BLACK	vis M6x20 NOIR		2
16	YC110-03-01	Rubber washer d6xd18x4mm	joint caoutchouc d6xd18x4mm		2
3	GB96-d6-W	Washer d6xd18mm	Rondelle d6xd18mm		3
14	YC50-1425-01	Plastic for Motor Front 50E 2016	Plaque Plastique Caisson avant		1

15	YC50-1426-01	Plastic for Motor Right 50E 2016	Caisson Plastique Droit YCF50E Noir		1
16	YC50-1427-01	Plastic for Motor Left 50E 2016	Caisson Plastique Gauche YCF50E Noir		1
17	YC50-1428-01	Complete Plastic for Motor 50E 2016	Caisson Plastique Complet YCF50E Noir		1
19	GB70-M8x16	Hex. Bolt M8x16	vis M8x16		1
20	GB818-M5x12-W	Plus screw M5x12	vis M5x12		1
21	GB5787-M6x16-W	Plus screw M6x16	vis M6x16		4
22	GB70.2-M6x16	Plus screw M6x16	vis M6x16		2
18	RCSC-BK	Right crankcase small Cover 88/125 2014 BLACK	DEMI CARTER EMBRAYAGE NOIR 88/125		2
23	GB70.2-M6x16	Plus screw M6x16	vis M6x16		4

ELECTRIC



N°	Ref.	Description	Français	Picture	Qty/Bike
1	YC50-1521-01	Controller XK-033 48V 35A 1200w	Controlleur XK-033 48V 35A 1200w		1
2	YC50-1627-01	Support of Motor Plastic	Support Controlleur		1
3	GB70-M6x12	Hex. Bolt M6x12	vis M6x12		4
4	GB97-d6-W	flat washer d6	rondelle d6		4

5	YC50-1511-01	Lithium battery 10A 48V 166x157x92mm	Batterie Lithium 10A 48V 166x157x92mm		1
6	YC50-1523-02	Battery protection 50E	Maintient mousse batterie		1
7	YC50-1508-02	Battery fixed 50E	Fixation Batterie		1
8	YC50-1534-01	Rubber Battery fixed	Caoutchouc pour maintient batterie		5
9	FB13-6x12x9-W	Battery fixed spacer d6xd12x9	Entretoise Maitient Batterie d6xd12x9		2
10	GB70.2-M6x20	Hex. Bolt M6x20	vis M6x20		2
11	YC50-1514-02	Charger 50E 2016	Chargeur Batterie YCF50E 2016		1
12	YC50-1513-01	Charge plug 50E 2016	Prise Chargeur YCF50E		1
13	GB846-ST2.9x10-W	Screw ST2.9x9.5	Vis ST2.9x9.5		2
14	YC50-1544-01	Potentiometer L=170mm	Potentiometre L=170 mm		1
31	YC50-1544-02	Speed governor L=310mm	Regulateur temps reponse acceleration YCF50E		1
15	YC50-1545-01	Locking piece for Speed governor	Piece Acier		1
	GB97-d6-W				1
16	GB818-M6x16-W	Plus screw M6X16	Vis M6X16		1
17	YC110-0021-02	Key contactor Waterproof 2018	Contacteur a cle 2018		1
17	YC110-1531-04	Key contactor bracket YCF50A 2018	Support contacteur a cle YCF50A 2018		1



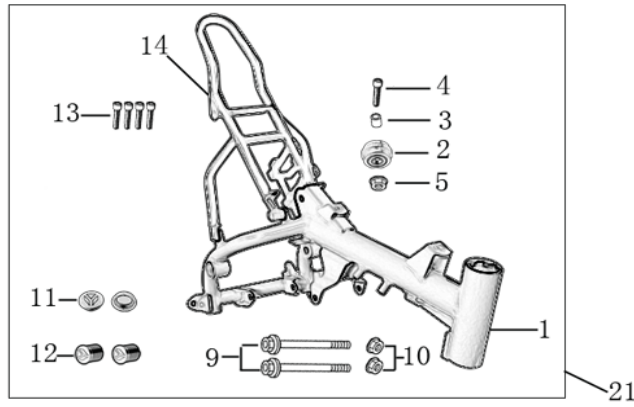



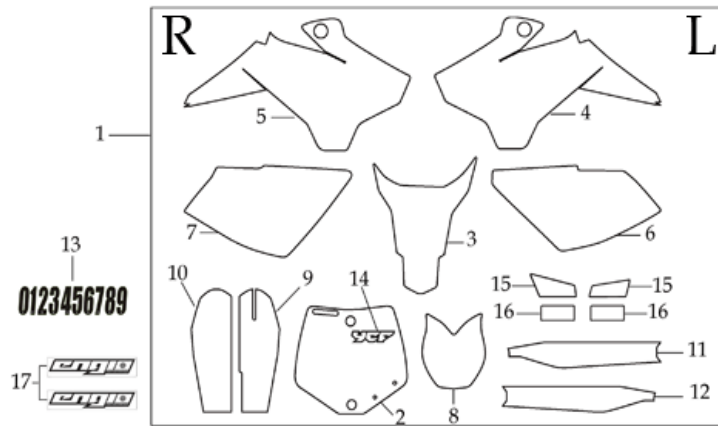

Frame







N°	Ref.	Description	Français	Picture	Qty/Block
1	YC50-173-01-WH	Frame 50E 2016 WHITE	Cadre 50E 2016 BLANC		1
2	YC50-2201	YCF Chain tensioner component	roulette chaine YCF		1
	YC50-2201-01	bushing d10xd14x10mm	entretoise d10xd14x10mm		1
	GB70-M10x50x1.5W	Hex. Bolt M10x50	Vis M10x50		1
	GB6187-M10-1.5-W	Self-locking Nut M10	écrou M10		1
9	GB5787-M8x95-W	Hex. Bolt with flanger M8x95	vis M8x95		2
10	GB6187-M8-W	Self locking nut M8	ecrou M8		2
11	YC50-1210	Rubber cover (swing arm axle) 电门锁位置	Capuchon cadre (axe bras)		3
12	YC50-1211	Rubber cover (bottom of frame) 50CC	Capuchon cadre (dessous cadre) 50CC		2
13	GB70-M8x16	Hex. Bolt M8x16	vis M8x16		4
14	YC50-16-03-BK	Rear Sub frame part 50E 2016 Steel Black	Boucle Arriere Acier Noire		1
21	YC50-1621-02-WH	complète frame 50E 2016 WHITE	cadre complet 50E 2016 BLANC		1







N°	Ref.	Description	Français	Picture	Qty/Blake
1	KD50E2019	YCF 50E complete graphic kit 2019	Kit deco complet YCF 50E 2019		1
	YC110-2519-01		Regulateur poignee Acceleration		1
	YC110-1901	Sticker Chain	Autocollant Chaîne		1
	YC110-1902	Sticker Tire	Autocollant Pression Pneu		1
	YC110-1903	Sticker Warning OIL Level	Autocollant Attention Niveau Huile		1
	YC110-1904	Sticker Rear Mudguard F125 70x57mm	Autocollant garde boue arriere F125 70x57mm		1
	YC110-1904-01	Sticker Rear Mudguard 50E 77x85mm	Autocollant garde boue arriere 50E 77x85mm		1
	YC110-1905	Sticker CE	Autocollant CE		1
	YC110-1906	Warning sticker	Sticker Attention		1
	YC110-1907	Warning Sticker Transport	Sticker Caisse Avertissement Transport		1
	YC110-1908	Warning Sticker Shok Absorber	Sticker Avertissement Amortisseur		1
ENGINES					
	MOTOR-50E	Motor XYD-14D 48V 1200W 2800rpm	Moteur 48V 1200W 2800rpm		1

GB70.2-M8x20	screw M8x20	vis M8x20		3
GB93-d8-W	Standard spring washer d8	rondelle d8		3
GB97-d8-W	flat washer d8	rondelle d8		3
RS35/10T	Sprocket(10T) 50E 换图	PSB 10T 换图		1
GB70-M5x16	Hex. Bolt M5x16	vis M5x16		1
GB96-d5-W	flat washer d5xd15	rondelle d5xd15		1
YC50-20-97	Sprocket cover	Protection PSB		1
GB70-M5x20-W	Hex. Bolt with Flanged Face M5X20	vis M5X20		3

CARTONS - CAISSES MOTOS

YC110-CARTON-50	BIKE BOX 50 YCF 1280x380x840mm	CARTON EMBALLAGE MOTO 50 1280x380x840mm		1
YC110-FOAMBOX	Foam box 2014 420x340x160mm	Cale PS		1
YC110-FILM	Protective film for seat 600x600x0.02mm	Protection plastique Selle		1
YC110-2101-03	Silicagel	Silicagel		5

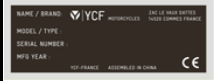
CATALOGUES - FICHES MOTOS - FICHES STICKER

YC110-0700-01	Accessory tools	Trousse a outils		1
YC110-0700-0203	Owner manual 50E 2016	Manuel Utilisation 50E 2016		1
YC110-0700-0401	Vin Plate 2015	Plaque Vin 2015		1
YC110-0700-03	A4 sheet assy	Fiche A4		1

50A1219/50E1619
50A1219/50E1619
50A1219/50E1619
50A1219/50E1619
50A1219/50E1619
50A1219/50E1619
50A1119/50E1619
ALL BIKES
ALL BIKES
ALL BIKES
50A1819/50E1819
50A1819/50E1819
50A1819/50E1819
50E1619
MODEL

50A1219/50E1619/F88L1719/F125L1619/F150L1719
50A1419/50E1619
50A1419/50E1619
50A1219/50E1619
ALL BIKES 1315 /ALL BIKES 1619 (BUT SP3)
50A1819/50E1819
50A1219/50E1619/F88L1719/F88s1319/F88se1519/F125L1619/F150L1719
50A1219/50E1619/F88L1719/F88s1319/F88se1519/F125L1619/F150L1719
ALL BIKES 1219
ALL BIKES 1219
ALL BIKES 1219
50A1219/50E1619/881012
ALL BIKES 201213/50A1419/50E1619/F88L1719/F88s1416/F88se1519/P88s1415/F125L16/F88L1719
50A1219/50E1619
ALL BIKES 1219
50A1219/50E1619
ALL BIKES 1219
50A1419/50E1619/F88s1416/F88se1519/P88s1415/F125L16
50A1419/50E1619/F88s1416/F88se1519/P88s1415/F125L16
ALL BIKES 1219

ALL BIKES 1219
50A1419/50E1619/F88s1416/F88se1519/P88s1415
50A1419/50E1619
50A1419/50E1619
50A1219/50E1619/F88L1719/F88s1316/F88se1619/F125L1619/F150L1719
ALL BIKES13/50A1419/50E1619/F88s1419/F88se1519/P88s1415/F125L16
50A1219/50E1619/F88s1216/F88se1519
50A1319/50E1619/F88s1316/F88se1519/F125L16
ALL BIKES 1219
MODEL
50A-E-1819
ALL BIKES
ALL BIKES
ALL BIKES

50A1219/50E1619
50A1219/50E1619
50A1219/50E1619
ALL BIKES 1219
50A1219/50E1619

MODEL
50A1619/50E1619
50A1619/50E1619
50A1219/50E1619/F88s1216/F88se1519/F88L1719
50A1219/50E1619/F88s1216/F88se1519/F88L1719
50A1319/50E1619
50A1219/50E1619
50A1319/50E1619

50A1219/50E1619/F88s1316/F88se1519
ALL BIKES
50A1219/50E1619/F88s1216/F88se1619/F88L1719
50A1619/50E1719
50A1219/50E1619
50A1219/50E1619
50A1219/50E1619
50A1219/50E1619
50A1219/50E1619
50A1219/50E1619
50A1219/50E1619
50A1619/50E1619
50A1619/50E1619
50A1619/50E1619
MODEL

50A1319/50E1619
ALL BIKES 1119
ALL BIKES 1119
ALL BIKES
ALL BIKES
ALL BIKES
50A1319/50E1619/F88s1316/F88se1519/F88L1719/F125L1619/F150L1719/F125s1316/F125s1319/F125se1519/SM125s1319
ALL BIKES 1319
50E1819
50E1819
50A1319/50E1619
MODEL
50A1219/50E1619
50A1219/50E1619

50A1219/50E1619
50E1619
ALL BIKES 1519 (BUT SP2/SP3/BIGYF150MX/FD190 MX)
50A1219/50E1619
ALL BIKES 1219
ALL BIKES 1119
50E1619
50E1619
ALL BIKES 1219
ALL BIKES 1119
50E1619
ALL BIKES 1319 (BUT SP1/SP2/SP3)
ALL BIKES 1319 (BUT SP1/SP2/SP3)
ALL BIKES 1319 (BUT SP1/SP2/SP3)
ALL BIKES 1319 (BUT SP1/SP2/SP3)
ALL BIKES 1119
ALL BIKES 1319
ALL BIKES 1419 (BUT SP1/SP2/SP3)
ALL BIKES 1417 (BUT SP1/SP2/SP3)

50A1219/50E1619

ALL BIKES 1419 (BUT
SP1/SP2/SP3)



MODEL

50A1219/50E1619

ALL BIKES 1215 (BUT SP1/SP2/SP3) /
ALL BIKES 1619 (BUT SP2/SP3)

ALL BIKES 1519 (BUT SP2/SP3)

ALL BIKES 1519 (BUT SP2/SP3)

50A1219/50E1619

ALL BIKES 0919

50A1219/50E1619

ALL BIKES 1219

50A1319/50E1619

50A1319/50E1619

50A1219/50E1619/LITE17
50A1219/50E1619/LITE17
50A1219/50E1619
50A1219/50E1619
ALL BIKES 1219
50E1619
50E1619
50A1219/50E1619



MODEL
50E1619
50A1219/50E1619
50A1219/50E1619/F88s1316/F88se1519
ALL BIKES

50A1219/50E1619/F88s1216/F88se1619/F88L19
50A1219/50E1619
50A1219/50E1619
50A1219/50E1619/F88s1216/F88se1519/P88s1219
50A1219/50E1619
50A1219/50E1619
50A1419/50E1619
50E1619
ALL BIKES 1319 (BUT SP1/SP2/SP3/BIGY)
50A1219/50E1619
50A1619/50E1619
50A1219/50E1719
50A1219/50E1619/F88s1216/F88se1519/F88L1719/P88s1215
50A1319/50E1619
50A1219/50E1619/F88s1216/F88se1519/F88L1719/P88s1315



MODEL
50A1219/50E1619
50A1219/50E1619
50A1219/50E1619
50A1219/50E1619
50A1219/50E1619
50A1219/50E1619
50A1419/50E1619
50A1419/50E1619
50A1419/50E1619

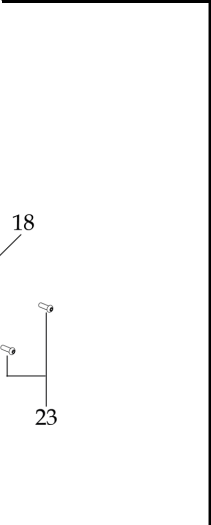

MODEL

50E1619
50E1619
50E1619
50A1219/50E1619
50E1619
ALL BIKES 1219
50A1219/50E1619
50E1619
50A1219/50E1619

MODEL
50E1619
50E1619
50A1219/50E1619
ALL BIKES 1219

50E1619
50E1619
50E1619
50E1619
50E1619
50E1619
50E1619
50E1619
50E1619
50E1619
50E1619
50E1619
50E1619
50E1619
50E1619
50E1619
ALL BIKES 1219
50A1219/50E1619
50A1819/50E1819/F88se1819/ F125se1819
50A1819/50E1819/F88se1819/ F125se1819



MODEL
50E1619
50A1219/50E1619
50A1219/50E1619
50A1219/50E1619
50A1219/50E1619
50A1219/50E1619
50A1219/50E1619
ALL BIKES
50A1719/50E1619
50A1219/50E1619
50A1219/50E1619
50E1619
50E1619

50E1619
ALL BIKES 1219
ALL BIKES 1119
50E1619
50A1619/50E1619
ALL BIKES 1519
50A1319/50E1619
50A1319/50E1619
50A1219/50E1619
ALL BIKES 1419
ALL BIKES 1419
ALL BIKES 19
ALL BIKES
50E1619
ALL BIKES 1319
ALL BIKES