



YCF-Parking.com

YCF 50A

2019

BIKE CODE FOR ORDERS:	19-50A-STD	BIKE DESCRIPTION NAME:	YCF 50A
-----------------------	------------	------------------------	---------



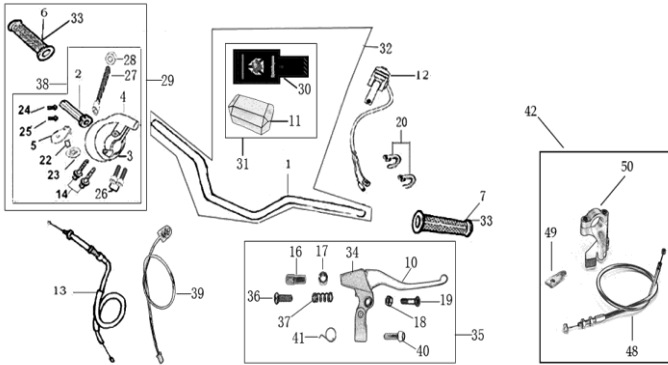

**Handle bar assembly**





N°	Ref.	Description	Français	Picture	Qty/ Bike	Model
1	YC50-0101-01	Handle Bar YCF50 Chromelly L=570mm STEEL	Guidon YCF50 chromolly L=570mm		1	50A1219/50E1619
2	YC110-01021-01	YCF Throttle Body 2012 BLACK	plastique poignée de gaz YCF 2012 NOIR		1	ALL BIKES 1219
3	YC110-01021-04	YCF Lower Throttle Body Housing 2012	dessous poignée gaz YCF 2012		1	50A1219/F88L19/F88s1219/ F88se1619/F125L1619/F150 L18F1251219/F125s1219/F1 25se1619/P88s1215/P12514 19/SM125s1419
4	YC110-01021-03	Upper Throttle Body Housing YCF 2012	dessus poignée gaz YCF 2012		1	ALL BIKES 1219
5	YC110-01021-02	Upper Throttle Body Housing Cover YCF 2012	plastique du dessus poignée gaz YCF 2012		1	ALL BIKES 1219
33	PPC010-GY	YCF set of grip GREY	Paire de poignée caoutchouc YCF GRISE		1	ALL BIKES 1219
6	YC110-01-01-GY	YCF Right Grip GREY	poignée caoutchouc droite YCF GRISE		1	ALL BIKES 1219
7	YC110-01-02-GY	YCF Left Grip GREY	poignée caoutchouc gauche YCF GRISE		1	ALL BIKES 1219
11	YC50-0110-01	Bar pad for Handlebar YCF50 126x75x45mm	Mousse guidon pour Guidon YCF50 126x75x45mm		1	50A1219/50E1619
12	YC110-0105-03	YCF50 Kill Switch ON/OFF L=500MM	Coupe circuit on off YCF50 L=500MM		1	50A1119/50E1619
13	YC50-0106-02	YCF50 Throttle Cable L=530mm A+B=125 2015	Cable gaz YCF50 L=530mm A+B=125 2015		1	50A1519

	YC110-0143-01	RUBBER ON THROTTLE CABLE			1	ALL BIKES 1719 (BUT50E)
20	YC110-01-03-BK	Tape 150mm BLACK	colier maintien cable 150mm NOIR		2	ALL BIKES
20	YC110-01-03-WH	Tape 150mm WHITE	colier maintien cable 150mm BLANC		2	ALL BIKES
20	YC110-01-05-BK	Tape 350mm BLACK	colier maintien cable 350mm NOIR		5	ALL BIKES
22	YC110-0102-08	YCF Throttle cable Bearing d8xd16x5mm	Roulement poignee gas YCF d8xd16x5mm		1	ALL BIKES 1219
23	YC110-0102-07	YCF Throttle cable guide pulley plastic d12xd16xd28x8mm	Roulette plastique Poignee Gas YCF d12xd16xd28x8mm		1	ALL BIKES 1219
24	GB819-M4x12	Plus screw M4x12 for Upper Throttle Body Housing Cover	vis M4x12 plastique du dessus poignée gaz		1	ALL BIKES 1219
25	GB819-M4x20	Plus screw M4x20 for Upper Throttle Body Housing Cover	vis M4x20 plastique du dessus poignée gaz		1	ALL BIKES 1219
26	GB70-M6x20-B	Hex. Bolt M6x20 BLACK	vis M6x20 NOIR		2	ALL BIKES 1219
27	GB70-M5x50	Hex. Bolt M5x50 To adjust YCF Throttle assy	vis M5x50 Pour réglage poigne de gas YCF		1	50A1219
28	GB6170-M5-W	Nut M5	ecrou M5		1	50A1219
30	YC50-0130-02	PVC for Bar Pad YCF50 89x243mm 2018 BLACK/WHITE	PVC mousse guidon YCF50 89x243mm 2018 NOIR		1	50A1819/50E1819
31	YC110-0131-01	Complete Bar Pad for Handlebar without Bar L=126mm YCF50 2018 BLACK/WHITE	Mousse guidon complete pour guidon Aluminium sans Barre YCF50 2018 L=126mm NOIR		1	50A1819/50E1819
32	YC110-0132-02	Handle Bar Chromelly (with bar pad and pvc) YCF50 2018 BLACK/ WHITE	Guidon Chromolly complet avec mousse et pvc YCF50 2018		1	50A1819/50E1819
35	YC50-01031	YCF50 Complete rear brake assy	Levier frein arriere complet YCF50 avec cocotte		1	50A1219/50E1619
10	YC50-0502-02	YCF50 Rear Brake lever (left side) L=128MM	Levier frein arriere (levier gauche) YCF50 L=128MM		1	50A1219/50E1619
41	YC50-1206	Spring for rear brake bracket M14x17	Ressort pour frein arriere M14x17		1	50A1219/50E1619
34	YC50-0502-01	YCF50 Rear (left side) brake bracket YCF50	Cocotte frein arriere YCF50 (cote gauche)		1	50A1219/50E1619
	YC50-0116	Adjust bolt M10x15mm	vis cocotte frein M10x15mm		1	50A1219/50E1619
	YC50-0117	YCF50 Tight Nut M10	Ecrou cocotte frein YCF50 M10		1	50A1219/50E1619
	FB02-M5x18	YCF50 Stepped bolt M5X18	Vis YCF50 M5X18		1	50A1219/50E1619
	YC50-0136	Spring M4x15 to adjust rear brake lever	Ressort M4x15 pour réglage frein arriere		1	50A1219/50E1619
	YC50-1206	Spring for rear brake bracket M14x17	Ressort pour frein arriere M14x17		1	50A1219/50E1619
	GB6189-M5	Self-lock Nut M5	ecrou M5		1	50A1219/50E1619
	GB818-M4x15	Screw M4x15	Vis M4x15		1	50A1219/50E1619



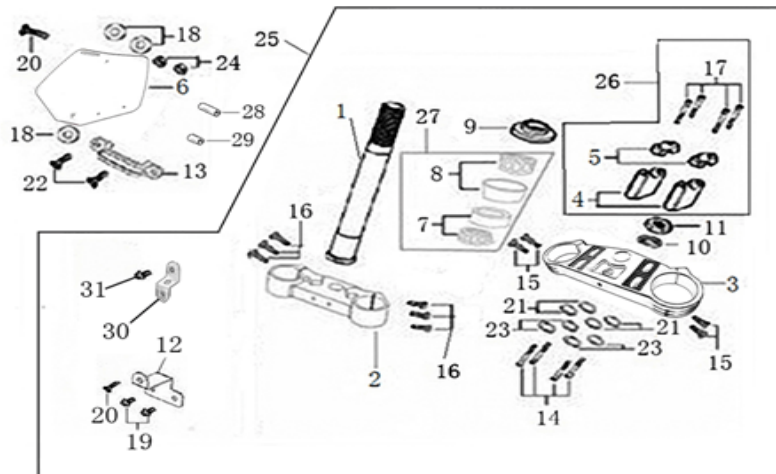



	GB70.2-M6x16	Screw M6x16	Vis M6x16		1	50A1219/50E1619
38	YC50-01021-N	YCF Throttle Assy. 50CC 2012 without grip(with YC110-0102-08 1EA+GB6170-M5 1EA)	Poignee gaz reglable YCF 50CC 2012 nue		1	50A1219
39	YC50-0105-01	YCF50 Start switch L=500mm	Bouton demareur YCF50 L=500mm		1	50A1219/F88se1516/F125se1516
42	YC50-0142-01	Air door assembly L=440mm A+B=50mm	Starter au Guidon Complet L=440mm A+B=50mm		1	50A1619
48	YC50-0148-01	Air door wire L=440mm A+B=50mm	Cable pour Starter au Guidon L=440mm A+B=50mm		1	50A1619
50	YC50-0150-01	Air door bracket assembly 50A	Starter au Guidon (Partie plastique)		1	50A1619
	YC50-0143-01	Air door upper bracket d21mm	Demi cocotte haute starter au guidon		1	50A1619
	YC50-0144-01	Air door lower bracket d21mm	Demi cocotte basse starter au guidon		1	50A1619
	YC50-0145-01	Air door spacer	Entretoise starter au guidon		1	50A1619
	YC50-0146-01	Air door Throwout lever	Manette stater au guidon		1	50A1619
	YC50-0147-01	Washer	Rondelle crante starter au guidon		1	50A1619
	GB70-M5x16	Hex. Bolt M5x16	Vis M5x16		1	50A1619/50E1619
	GB70-M5x20	Hex. Bolt M5x20	Vis M5x20		1	50A1619
	GB6170-M5-W	Nut M5	Ecrou M5		2	50A1619

### Steering stem assembly

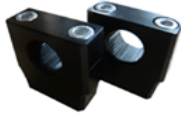





N°	Ref.	Description	Français	Picture	Qty/ Bike	Model
1	YC50-0200-01	Steering stem 195 mm	tige colonne direction 195 mm		1	50A1219/50E1619/F88L1719/F125L1619/F150L1719

2	YC50-0202-05-GY	Lower triple clamp YCF50 135mm 2014 GREY	té fourche inferieur YCF50 135mm GRIS		1	50A1419/50E1619
3	YC50-0201-05-GY	Top Triple Clamp YCF50 135mm 2014 GREY	té fourche supérieur YCF50 135 mm GRIS		1	50A1419/50E1619
4	YC50-0203-04	YCF50 Lower Bar Mount CNC 35 mm BLACK	Pontet guidon inférieur YCF50 35mm NOIR		2	50A1419/50E1619
5	YC110-0202-04	Top Bar Mout CNC d22.2 mm/height 18mm START Type BLACK	pontet guidon supérieur d22.2 mm Type START NOIR		2	ALL BIKES 1319 (BUT SP3/8IGYFD190MX)
6	YC50-0212-02-WH	YCF Front Number Plate 50cc WHITE	plaque avant BLANCHE YCF 50cc		1	50A1819/50E1819
7	297-41/24	Lower Taper roller bearing 41/24	roulement inférieur 41/24		1	50A1219/50E1619/F88L1719/F88s1319/F88se1519/F125L1619/F150L1719
8	297-41/22.5	Top Taper roller bearing 41/22.5 R START 08	roulement supérieur 41/22.5		1	50A1219/50E1619/F88L1719/F88s1319/F88se1519/F125L1619/F150L1719
9	YC110-02-09	Top nut for steering d52	écrou crantellé colonne direction d52		1	ALL BIKES 1219
10	YC110-02-10	Washer for steering stem nut d22.5xd36x0.7	joint colonne direction d22.5xd36x0.7		3	ALL BIKES 1219
11	YC110-02-11	Nut for steering stem M22	écrou supérieur colnne direction M22		1	ALL BIKES 1219
12	YC110-0213-02	Number plate bracket short L=60mm H=33mm	support plaque avant courte L=60mm H=33mm		1	50A1219/50E1619/881012
13	YC110-02-14-WH	Break Line Retainer White	guide durite sur plaque avant Blanc		1	ALL BIKES 201213/50A1419/50E1619/F88L1719/F88s1416/F88se1519/P88s1415/F125L16/F88L1719
14	GB70-M8x20	Stud screw M8X20	vis M8X20		4	50A1219/50E1619
16	GB70-M8x25	Stud screw M8X25	vis M8X25		8	50A1219/50E1619
17	GB70-M8x20	Stud screw M8X20	vis M8X20		4	50A1219/50E1619
18	GB97-d6-W	flat washer d6	rondelle d6		1	ALL BIKES 1219
19	GB5787-M6x16-W	Hex. Bolt with Flanged Face M6X16	vis M6X16		2	ALL BIKES 1219
20	GB9074.5-M6x16-W	Plus screw M6X16 (for bottom front No plate)	vis m6x16 bas plaque No avant		1	50A1419/50E1619/F88s1416/F88se1519/P88s1415/F125L16
20	GB9074.5-M6x25-W	Plus screw M6X25 (for top front No plate)	vis m6x25 haute plaque No avant		1	50A1419/50E1619/F88s1416/F88se1519/P88s1415/F125L16
21	GB97-d4-W	flat washer d4	rondelle d4		1	ALL BIKES 1219
22	GB818-M4x10-W	Plus screw M4x10	vis M4x10		1	ALL BIKES 1219
23	GB93-d8-W	Spring washer d8mm	rondelle d8mm		4	ALL BIKES 1219
24	GB6170-M4-W	Nut M4	ecrou M4		2	50A1419/50E1619/F88s1416/F88se1519/P88s1415

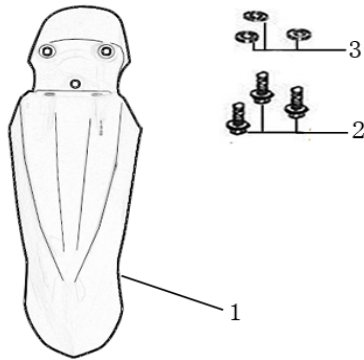
25	YC50-0227-02-GY	Complete Triple Clamp YCF50 135mm 2014 GREY	Te Fourche Complet YCF50 135mm 2014 GRIS		1	50A1419/50E1619
26	YC50-0228	YCF50 Set of Bar mount not adjustable d22.2 mm/bottom 35mm(with GB70-M8x20 8EA+GB93-d8-W 4EA)	Jeu pontet guidon YCF50 non ajustable d 22.2 mm / pontet bas 35mm		1	50A1419/50E1619
27	KRDIRECTION41-2	set of bearing for steering 41/24、 41/22.5	kit rit colonne direction 41/24、 41/22.5		1	50A1219/50E1619/F88L1719/F88s1316/F88se1619/F125L1619/F150L1719
28	FB13-9x10x17-W	Front Number plate spacer (Top) d 8.5x10x17	entretoise Plaque numero avant (Haut) d 8.5x10x17		1	ALL BIKES13/50A1419/50E1619/F88s1419/F88se1519/P88s1415/F125L16
29	FB13-9x10x6-W	Front Number plate spacer (Bottom) d 8.5x10x5.5	entretoise Plaque numero avant (Bas) d 8.5x10x5.5		1	50A1219/50E1619/F88s1216/F88se1519
30	YC110-0213-04	Number plate bracket long TOP BLACK	support plaque avant NOIR		1	50A1319/50E1619/F88s1316/F88se1519/F125L16
31	GB5787-M6x10-W	Hex. Bolt M6X16	vis M6x16		1	50A1219/F88s1316/F88se1619

### Front Fender







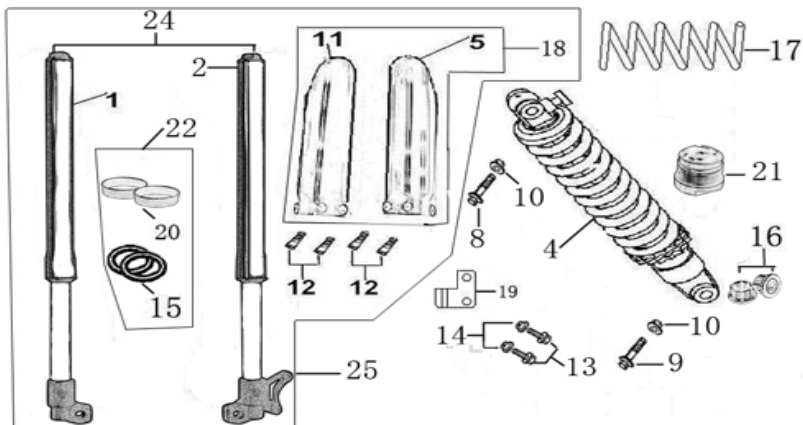









N°	Ref.	Description	Français	Picture	Qty/ Bike	Model
1	YC50-031WH	Front Fender YCF50 RED	Gb avant YCF50 ROUGE		1	50A-E-1819
2	GB5787-M6x20-W	Hex. Bolt with flanged M6X20	vis M6X20		3	ALL BIKES
3	GB96-d6-W	Washer d6xd18mm	Rondelle d6xd18mm		3	ALL BIKES
3	YC110-03-01	Rubber washer d6xd18x4mm	caoutchouc d6xd18x4mm		3	ALL BIKES

### Front & Rear absorber





N°	Ref.	Description	Français	Picture	Qty/ Bike	Model
1	YC50-0401-04	Front right fork 530 mm (not adjustable) MAGNESIUM	tube fourche droit 530 mm MAGNESIUM		1	50A1319/50E1619

2	YC50-0402-04	Front left fork 530mm (not adjustable) MAGNESIUM	tube fourche gauche 530 mm MAGNESIUM		1	50A1319/50E1619
4	YC50-0404-03	YCF50 Shock absorber L=200mm 2014 YELLOW	Amortisseur YCF50 L=200mm 2014 JAUNE		1	50A1419/50E1619
16	YC50-0410-02	shock top spacer 50CC 2014 d10xd22x21.5mm	Silent Block haut amortisseur 50CC 2014 d10xd22x21.5mm		1	50A1419/50E1619
16	YC50-0411-03	shock bottom spacer 50CC 2014 d10xd20xd26x11mm	Silent Block bas amortisseur YCF50 d10xd20xd26x11mm		2	50A1419/50E1619
5	YC50-04-01-WH	Left front fork protection YCF50 L=530mm WHITE	Protection fourche gauche YCF50 L=530mm BLANC		1	50A1419/50E1619
	YC50-0421-WH	YCF50 Brake Cable clip WHITE	Capot passe durite frein avant YCF50 BLANC		1	50A1419/50E1619
	GB70-M4x15	Hex. Bolt M4x15	vis M4x15		2	50A1419/50E1619
	GB6170-M4	Nut M4	ecrou M4		2	50A1419/50E1619
8	GB5787-M10x45	Hex.bolt for shock absorber M10x45	Vis amortisseur M10x45		2	50A1419/50E1619
10	GB6187-M10-W	Self-locking Nut M10	Ecrou vis amortisseur M10		2	50A1419/50E1619
11	YC50-04-02-WH	Right front fork protection YCF50 L=530mm WHITE	Protection fourche droite YCF50 L=530mm BLANC		1	50A1419/50E1619
12	GB70.2-M5x12	Plus screw M5x12	vis M5x12		4	50A1419/50E1619
	GB97-d5-W	Flat washer d.5	rondelle d.5		4	50A1419/50E1619
18	YC50-0418WH	YCF50 set of fork protection WHITE	Jeu protection fourche YCF50 BLANC		1	50A1419/50E1619
24	YC50-0400-03	YCF50 Pair of fork 530mm d35 (not adjustable) MAGNESIUM	Jeu de fourche YCF50 530mm d35 MAGNESIUM		1	50A1419/50E1619

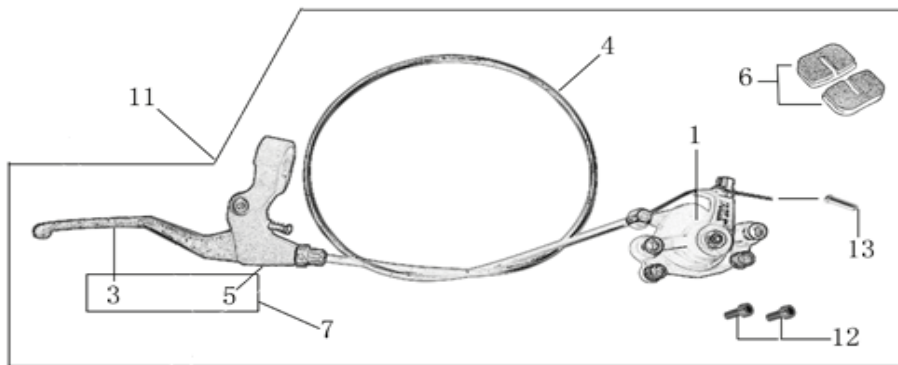
### Front Brake Assy









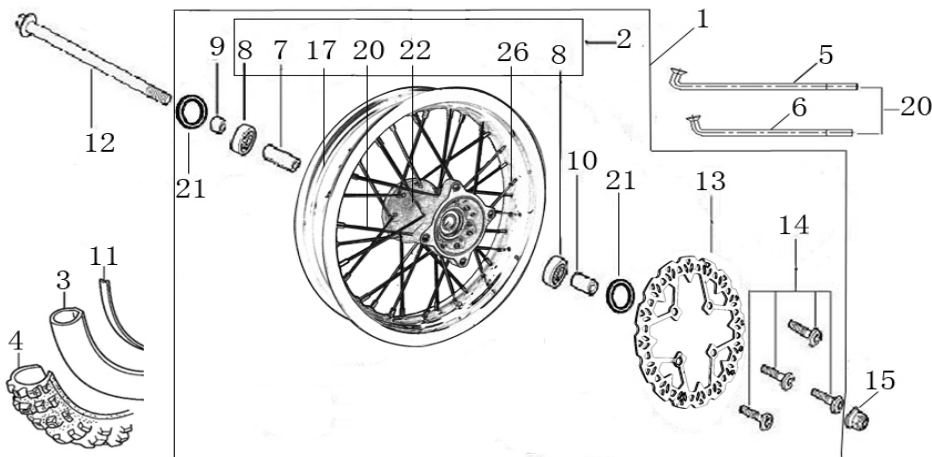











N°	Ref.	Description	Français	Picture	Qty/ Bike	Model
1	YC50-0502	YCF50 Front Brake caliper	Etrier frein avant YCF50		1	50A1219/50E1619
4	YC50-0501-03	YCF 50 Front brake cable 730mm.(with YC50-0513 1EA)	cable frein avant YCF50 730mm		1	50A1219/50E1619
	YC50-0501	YCF50 Complete front brake assy	Levier frein avant complet avec cocotte YCF50		1	50A1219/50E1619

3	YC50-0501-02	Front Brake lever (right side) L=143MM	levier frein pour (levier droit) L=143MM		1	50A1219/50E1619
	YC50-0515	Spring for front brake bracket M14x17	Ressort pour frein avant M14x17		1	50A1219/50E1619
5	YC50-0501-01	YCF50 Rear (right side) brake bracket 2012	Cocotte frein arriere YCF50 (cote droit) 2012		1	50A1219/50E1619
	YC50-0116	Adjust bolt M10x15mm	vis cocotte frein M10x15mm		1	50A1219/50E1619
	YC50-0117	YCF50 Tight Nut M10	Ecrou cocotte frein YCF50 M10		1	50A1219/50E1619
	FB02-M5x18	YCF50 Stepped bolt M5X18	Vis YCF50 M5X18		1	50A1219/50E1619
	YC50-0136	Spring M4x15 to adjust rear brake lever	Ressort M4x15 pour réglage frein arriere		1	50A1219/50E1619
	YC50-0515	Spring for front brake bracket M14x17	Ressort pour frein avant M14x17		1	50A1219/50E1619
	GB6189-M5	Self-lock Nut M5	ecrou M5		1	50A1219/50E1619
	GB818-M4x15	Screw M4x15	Vis M4x15		1	50A1219/50E1619
	GB70.2-M6x16	Screw M6x16	Vis M6x16		1	50A1219/50E1619
6	YC50-0506	YCF50 Front / Rear Brake pads	Jeu plaquette avant / arriere YCF50		2	50A1219/50E1619
11	YC50-0511	YCF50 front brake assy L=730mm	kit frein avant YCF50 L=730mm		1	50A1219/50E1619
	YC50-0513	Brake cable caps 50CC	Embout Cables frein 50CC		1	50A1219/50E1619
12	GB70-M6x25	Stud screw M6x25	vis M6x25		2	50A1219/50E1619
	GB97-d6	Flat washer d.6	rondelle d.6		2	50A1219/50E1619
	GB93-d6-W	Foot pegs bar washer d.6	rondelle d.6		2	50A1219/50E1619

### Front Wheel Assy



N°	Ref.	Description	Français	Picture	Qty/ Bike	Model
----	------	-------------	----------	---------	--------------	-------

1	YC50-0601-04	YCF50 Front wheel complete STEEL10",with brake& hardware. Casting hub . But without tire	roue avant complète 10' YCF50 moyeux injectée cerceau acier avec disque sans pneu ni chambre ni fond jante		1	50A1619/50E1719
2	YC50-0602-01	STEEL front wheel 10' without disk	roue avant ACIER sans disque 10'		1	50A1619/50E1719
3	CHAMBRE10-2.5	Tube for front tire 2.50-10' GL	chambre air 2.50-10' GL		1	50A1219/50E1619/F88s1316/F88se1519
	FB6170-M8-Cr	Tire valve nut M8	Ecrou Valve M8		1	ALL BIKES
4	250/10	Tire 2.50-10' GUANGLI	pneu 250-10' GUANGLI		1	50A1219/50E1619/F88s1216/F88se1619/F88L19
5	YC50-0605	outer spoke for 10wheel, 106 mm 10K	Rayon extérieur 106 mm pour roue AV 10'		16	50A1219/50E1619
6	YC50-0622	inside spoke for 10wheel, 104mm 10K	Rayon interieur 104 mm pour roue AV 10'		8	50A1219/50E1619
	S11110K	outside spoke for 10wheel, 111mm 10K	Rayon exterieurr 111 mm pour roue AV 10'		8	50A1219/50E1619
	JR10-10.6	set of spoke 10' 50cc 2012 (104mmx8+106mmx16+111mmx8)	JEUX RAYON AV 10' 50cc 2012 (104mmx8+106mmx16+111mmx8)			50A1619/50E1719
7	YC50-0607-01	Front axle bushing 50A d14xd20x46	entretoise centrale roue avant 50A d14xd20x46		1	50A1219/50E1619
8	6201RS	YCF50 Ball bearing 6201RS d32xd12x10mm	Roulement roue 6201RS d32xd12x10mm YCF50		2	50A1219/50E1619
9	YC50-06-052	YCF50 Right wheel spacer d12xd22x23	entretoise roue avant droite d12xd22x23 YCF50		1	50A1219/50E1619
10	YC50-06-051	Left wheel spacer d12xd22x26	entretoise roue avant gauche d12xd22x26		1	50A1219/50E1619
11	YC110-11-02	Tire lining for 12'	fond jante av 12'		1	50A1219/50E1619/F88s1216/F88se1519/F88L1719
12	YC50-06-01	YCF50 Front Axle 170 mm with Self-locking nut d12	Axe de roue avant d12 L=170MM YCF50		1	50A1219/50E1619
15	GB6187-M12xP-W	Self-locking nut M12	écrou roue avant M12		1	50A1219/50E1619
13	YC50-0513-01	Front disk d160 mm 2016	disque frein avant d160mm 2016		1	50A1219/50E1619
14	GB70.2-M6x16	Socket head cap screw M6X16	vis disque frein M6X16		4	50A1219/50E1619
17	YC50-0617-01	STEEL Rim for Front wheel 1.4x10'	cerceau roue av 1,4x10' ACIER		1	50A1219/50E1619/F88s1216/F88se1519/F88L1719
21	YC50-0610	OIL SEAL d22xd32x5	joint spy roue d22xd32x5		2	50A1219/50E1619



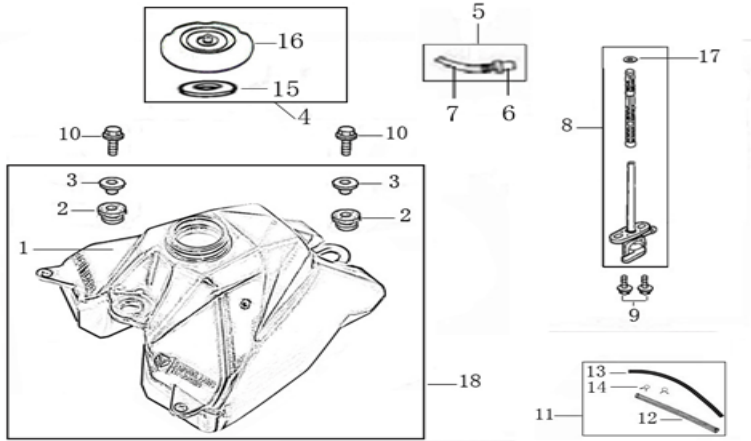

22	YC50-0622-02	YCF50 Front hub injected with washer	Moyeux avant injectée avec joint spy YCF50		1	50A1219/50E1619
----	--------------	--------------------------------------	--	--	---	-----------------

**Fuel Tank**





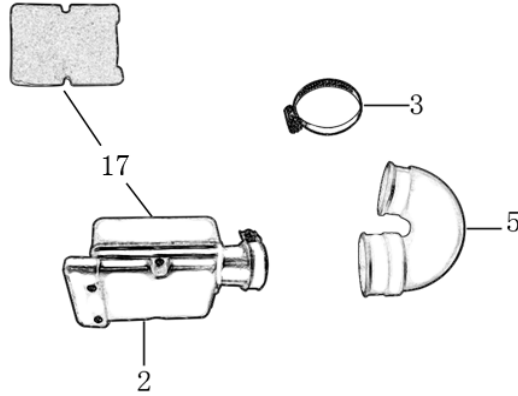

N°	Ref.	Description	Français	Picture	Qty/ Bike	Model
1	YC50-07012	YCF50 Fuel tank	Reservoir YCF 50cc		1	50A1319/50E1619
2	YC110-07-01	Cushion for fuel tank	caoutchouc pour reservoir		2	ALL BIKES 1119
3	YC110-07-02	Washer for fuel tank d12xd30x11mm	entretoise pour reservoir d12xd30x11mm		2	ALL BIKES 1119
4	YC110-0702-01	YCF Tank cap plastic 2013	Bouchon reservoir plastique YCF 2013		1	ALL BIKES 1119
5	YC125-0704-BK	Fuel tank valve BLACK	Valve prise air NOIR		1	ALL BIKES
6	YC110-0704-BK	Cap of Fuel tank valve BLACK	Capuchon Valve prise air NOIR		1	ALL BIKES
7	YC110-0705-BK	Fuel tank valve Hose L=40mm BLACK	Durite caoutchouc Vale prise air L=40mm NOIRE		1	ALL BIKES
8	YC110-0703	Fuel cock assy.	robinet essence		1	ALL BIKES
9	GB5787-M6x16-W	Plus screw M6X126for fuel cock	vis M6X16 pour robinet essence		2	ALL BIKES 1219
10	GB5787-M8x25-B	screw M8X25 BLACK for gas tank	vis M8x25 NOIR pour reservoir		2	50A1319/50E1619/F88s1316 /F88se1519/F88L1719/F125L 1619/F150L1719/F1251316/ F125s1319/F125se1519/SM1 25s1319
11	YC110-0706	fuel tank rubber line + spring d4.5xd8.5x210mm	durite reservoir avec ressort d4.5xd8.5x210mm		1	ALL BIKES
12	YC110-07061	fuel tank Ispring L=180mm	ressort durite reservoir L=180mm		1	ALL BIKES
13	YC110-07062	fuel tank rubber line d4.5xd8.5x210	durite reservoir d4.5xd8.5x210		1	ALL BIKES
14	YC110-07063	Holding ring	collier FILTRE		2	ALL BIKES

15	YC110-0720-02	Rubber mat for tank cap plastic d14xd52x2mm Oil proof	Caoutchouc bouchon reservoir YCF d14xd52x2mm		1	ALL BIKES 1319
17	YC50-0717	O-RING,d11x4mm For Fuel tank 50CC for fuel cock	Joint thorique robinet essence		1	50A1319
18	YC50-0718	YCF50 Complete fuel tank 2013(with YC110-07-01 2EA+YC110-07-02 2EA)	Reservoir complet YCF50 2013		1	50A1319/50E1619

### Air Filter



N°	Ref.	Description	Français	Picture	Qty/ Bike	Model
2	YC50-0801	Air box air filter assy d35	filtre air complet boite a air d35		1	50A19
3	YC50-0803	Holding ring d21-d44mm	collier FILTRE d21-d44mm		1	50A19
5	YC50-0805	YCF50 rubber connexion for air box	manchon boite air YCF50		1	50A19
17	YC50-0802	YCF50 Air filter Foam	Mousse filtre a air YCF50		1	50A19
	YC110-0835-01	YCF50 Air box fixed bracket	Plaque acier maintien boite air YCF50		1	50A1819

### Foot Peg assy

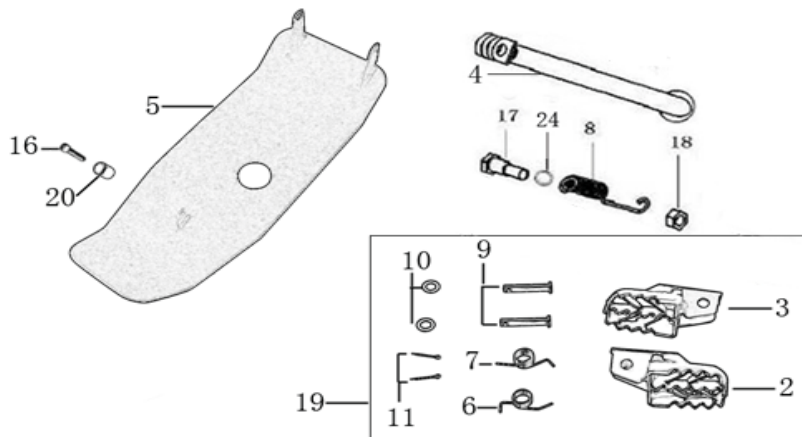

N°	Ref.	Description	Français	Picture	Qty/ Bike	Model
2	YC50-0902	YCF50 right foot pegs steel L=65mm GREY	Repose pied droit acier YCF50 L=65mm GRIS		1	50A1219/50E1619

3	YC50-0901	YCF50 left foot pegs steel L=65mm GREY	Repose pied gauche acier YCF50 L=65mm GRIS		1	50A1219/50E1619
4	YC110-198	Kick stand 225mm	bequille 225mm		1	50A1219/50E1619
5	YC50-204-01	YCF50 Engine skid plate steel T=2mm MATTE BLACK	sabot acier YCF50 T=2mm NOIR MAT		1	50A1319
	FB13-9x10x10-W	bushing skid plate d8.5xd10x10mm	entretoise Bras acier d8.5xd10x10mm		1	50A1319
6	YC110-09-01	Spring for right steel foot peg d1.5xd16.5x10mm	ressort repose pied droit acier d1.5xd16.5x10mm		1	ALL BIKES 1319 (BUT SP/BIGYF150MX/FD190MX)
7	YC110-09-02	Spring for left steel foot peg d1.5xd16.5x10mm	ressort repose pied gauche acier d1.5xd16.5x10mm		1	ALL BIKES 1319 (BUT SP/BIGYF150MX/FD190MX)
8	YC110-19-01	spring for kick stand d2.5xd15x105	ressort bequille d2.5xd15x105		1	ALL BIKES 1417 (BUT SP1/SP2/SP3)
9	GB882-d8x40-W	shaft pin for steel footpegs d8x40	axe repose pied acier d8x40		2	ALL BIKES 1417 (BUT SP1/SP2/SP3)
10	GB97-d8-W	flat washer d8x16x1	rondelle d8x16x1		2	ALL BIKES 1119
11	GB91-d2x25-W	Cotter pin 2.0x25	goupille 2.0x25		2	ALL BIKES 1319 (BUT SP/BIGYF150MX/FD190MX)
16	GB70-M8x20-W	Hex. Bolt M8x20	vis boucle arriere M8x20		1	50A1419
17	FB02-M10x1.5x30I	Stepped screw M10X35 for kick stand	vis bequille M10X35		1	ALL BIKES 1419 (BUT SP1/SP2/SP3)
18	GB6170-M10-G	Hex. Nut M10	ecrou bequille M10		1	ALL BIKES 1419 (BUT SP1/SP2/SP3)
19	YC50-0902/03	Steel set of foot pegs 50cc Grey	jeu repose pied acier 50cc Grise		1	50A1219/50E1619
24	GB93-d10-W	Standard spring washer d10	rondelle d10		1	ALL BIKES 1419 (BUT SP1/SP2/SP3)

### Swing Arm assy

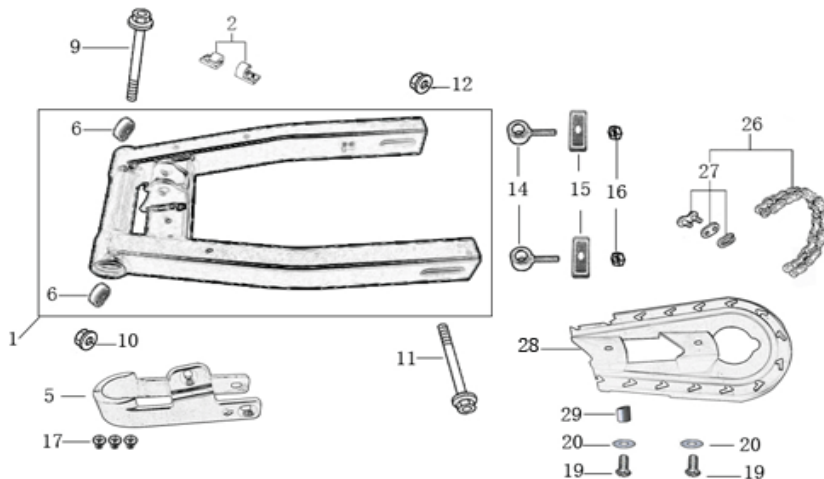

N°	Ref.	Description	Français	Picture	Qty/ Bike	Model
----	------	-------------	----------	---------	--------------	-------

1	YC50-10014	YCF50 Mono swing arm BLACK	bras oscillant mono YCF50 NOIR		1	50A1219/50E1619
2	YC110-10-014-BK	Rear brake clip for BLACK	attache durite frein arriere NOIR		1	ALL BIKES 1215 (BUT SP1/SP2/SP3) / ALL BIKES 1619 (BUT SP2/SP3)
17	GB819-M6x16-W	Plus screw M6X16	vis m6x16		5	ALL BIKES 1519 (BUT SP2/SP3/BIGYF150MX/FD190MX)
	GB6100-M6-CW	nut M6x25mm	Vis M6x25mm		5	ALL BIKES 1519 (BUT SP2/SP3/BIGYF150MX/FD190MX)
5	YC50-10-01	YCF Chain slider 50cc	patin chaine YCF 50cc		1	50A1219/50E1619
6	6001/28-12-08	Swing arm bearing d28xd12x8mm	roulement bras oscillant d28xd12x8mm		2	ALL BIKES 0909
9	YC50-1009	Swing arm shaft with self lock nut d12X190mm 用完后用192MM	axe bras oscillant d12x190mm		1	50A1219/50E1619
10	GB6187-M12-W	Self locking nut M12	ecrou bras oscillant M12		2	50A1219/50E1619
11	YC50-11-02	YCF50 Rear wheel axle M12x215 with Self locking nut M12	axe roue arriere YCF50 L=215mm avec ecrou d12		1	50A1319/50E1619
16	YC50-1001-001	YCF50 Block axle	Tendeur chaine YCF50		2	50A1319/50E1619
16	YC50-1001-002	YCF50 Block axle fixing plate	Patte acier fixation tendeur chaine YCF50		2	50A1219/50E1619/LITE 17
	GB6189-M8-W	Clth Self-lock Nut M8	ecrou M8		2	50A1219/50E1619/LITE 17
19	GB818-M6x16-W	Plus screw M6x16	vis M6x16		2	50A1219/50E1619
19	GB818-M6x25-W	Plus screw M6x25	vis M6x25		1	50A1219/50E1619
20	GB97-d6	Flat washer d6	rondelle d6		2	ALL BIKES 1219
26	420H-84	YCF50 Driving chain 420H-84T	Chaîne 420 84 maillons YCF50		1	50A1619
27	AR-420	Chain link	Attache rapide chaine		1	ALL BIKES 1219 (BUT 50E)
28	YC50-0600-02	YCF50 Chain box protection YCF50	Protection chaine plastique YCF50			50A1219/50E1619

### Rear Wheel Assy

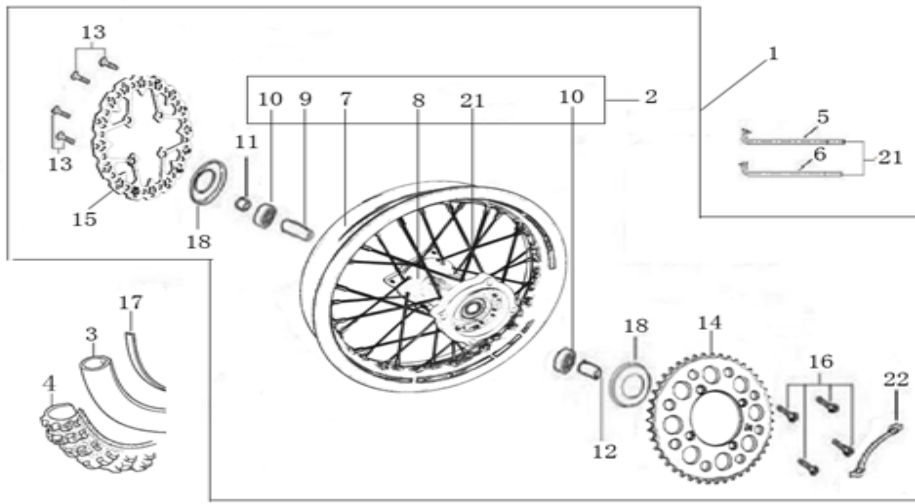

N°	Ref.	Description	Français	Picture	Qty/ Bike	Model
1	YC50-1101-04	YCF50 Complete STEEL Rear wheel 1.40-10' Casting hub with disk 2016	roue arriere complète YCF50 Acier 1.40-10 moyeux injecte avec disque		1	50A1619
2	YC50-1102-01	Complete STEEL Rear wheel 1.40x10' without disk	roue arriere complète ACIER 1.40x10' moyeux injecte sans disque		1	50A1619/50E1619
3	CHAMBRE10-2.5	Tube for Rear tire 2.50-10 GL	chambre air 2.50-10' GL		1	50A1219/50E1619/F88s 1316/F88se1519
	FB6170-M8-Cr	Tire valve nut M8			1	ALL BIKES
4	250/10	YCF tyre 2.50/10' GUANGLI	pneu 2.50/10' YCF GUANGLI		1	50A1219/50E1619/F88s 1316/F88se1519
5	YC50-0606	outer spoke for 10' wheel 111 mm	Rayon extérieur 111 mm pour roue AV 10'		16	50A1219/50E1619/F88s 1316/F88se1519
6	YC50-0605	inside spoke for 10' wheel 106 mm	Rayon interieur 106 mm pour roue AV 10'		16	50A1219/50E1619
7	YC50-1117-01	STEEL Rim 1.40x10'	cerceau roue 1,40x10 ACIER		1	50A1219/50E1619/F88s 1216/F88se1519/P88s1 215
8	YC50-1122-02	YCF50 Rear wheel hub Casting with seal	Moyeux arrière YCF50 injecte avec joint spy		1	50A1619/50E1619
10	6201RS	Ball bearing 6201RS d32xd12x10mm	roulement roue 6201RS d32xd12x10mm		2	50A1219/50E1619
12	YC50-11-041	Axle spacer, dd22xd12x25mm (left/right)	entretoise roue arrière (droit/gauche) d22xd12x25mm		2	50A1219/50E1619
14	YC110-11-06/45	YCF Driven sprocket 420-45T	couronne acier 45T YCF		1	50A1619/F125L1619/F1 50L1719/F1251216/F12 5s1219/F125se1519/P1 251319/P1501319/SM1 219
	YC110-11-03	Sprocket Locking piece	block couronne		2	ALL BIKES 1319 (BUT SP1/SP2/SP3/BIGY)

16	GB5783-M8x20-W	Exterior Hex.Bolt M8X20	vis couronne m8x20		4	50A1219/50E1619
15	YC50-0513-01	YCF50 disk d160 mm 2016	disque YCF50 d160mm 2016		1	50A1619/50E1619
13	GB70.2-M6x16	Socket head cap screw M6x16	vis de disque M6x16		4	50A1219/50E1619
17	YC110-11-02	Tire lining for 12'	fond jante 12'		1	50A1219/50E1619/F88s1216 /F88se1519/F88L1719
18	YC50-0610	OIL SEAL d22xd32x5	joint spy roue d22xd32x5		2	50A1319/50E1619
21	JR10-10.5	set of spoke 10' (106mmx16+111mmx16)	jeu rayon arrière 10' (106mmx16+111mmx16)		1	50A1219/50E1619/F88s1216/F88se1519/F88L1719/P88s1315

## REAR BRAKE

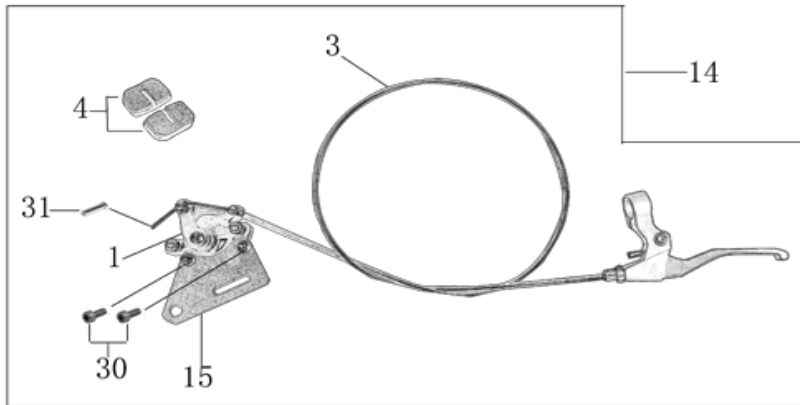

N°	Ref.	Description	Français	Picture	Qty/ Bike	Model
1	YC50-1201	YCF50 Rear Brake caliper	Etrier frein arriere YCF50		1	50A1219/50E1619
3	YC50-0502-03	YCF50 Rear brake steel line 1050mm A+B=120mm(with YC50-0513 1EA)	durite frein arriere YCF50 1050mm A+B=120mm		1	50A1219/50E1619
4	YC50-0506	Front / Rear Brake pads	jeu plaquette avant / arriere		2	50A1219/50E1619
14	YC50-1214	YCF50 Rear brake assy L=1050mm	Kit frein arriere YCF50 L=1050mm		1	50A1219/50E1619
	YC50-0513	Brake cable caps 50CC	Embout Cables frein 50CC		1	50A1219/50E1619
15	YC50-120101-02	Rear brake bracket T=3mm 2014	patte fixation étrier frein arriere T=3mm 2014		1	50A1219/50E1619
	FB13-7x10x4-W	bushing d7xd10x4mm	entretoise d7xd10x4mm		2	50A1419/50E1619
30	GB70-M6x12	Hex. Bolt M6x12	vis M6x12		2	50A1219/50E1619

## Exhaust system

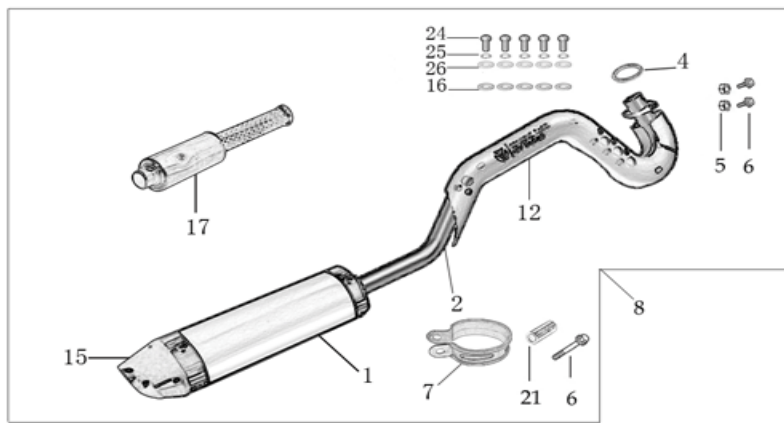

N°	Ref.	Description	Français	Picture	Qty/ Bike	Model
1	YC50-13016-GY	YCF50 Muffler L=240mm 2015 GREY	Silencieux YCF50 2015 GREY		1	50A1519
2	YC50-13010-02	Exhaust pipe d22mm 2014	collecteur d22mm 2014		1	50A1419
4	YC50-1304	Exhaust pipe washer d21xd15x4mm	joint pot d21xd15x4mm		1	50A1219
5	GB6170-M6-W	Hex flanged self locking nut M6	écrou M6		2	ALL BIKES
21	FB13-10x14x10-W	Muffler Hoop spacer Φ10xΦ14x10mm	Entretoise attache silencieux Φ10xΦ14x10mm		1	50A1319/P1251315/P1501315/SM1501315
6	GB5787-M8x30-W	Hex. Bolt with flanged M8x30	vis M8x30		1	50A1319/P1251319/P1501319/SM1501319
7	YC50-13-01	Hoop for muffler YCF50(with FB13-Φ10xΦ14x10-W 1EA+GB5787-M8x35-W 1EA )	Attache silencieux YCF50		1	50A1219
8	YC50-132-02-GY	YCF50 Muffler& Exhaust pipe assy 2015 GREY	Echappement complet YCF50 2015 GRISE		1	50A1519
12	YC50-1312-01	YCF50 protection for exhaust pipe 2014(3PCS)	Grille pot YCF50 2014		1	50A1419
24	GB70.2-M6x10-Cr	Plus screw M6x10	vis M6x10		3	ALL BIKES 1219
25	GB93-d6-W	Standard spring washer d6	rondelle d6		3	ALL BIKES 1219
26	GB97-d6-W	flat washer d6	rondelle d6		3	ALL BIKES 1219
15	YC50-13-33	YCF50 Muffler end cap YCF	Embout silencieux YCF50		1	50A1219
	GB70-M4x16	Hex. Bolt M4x16	vis M4x16		4	50A1219
24	GB93-d4-W	Standard spring washer d4	rondelle d4		4	50A1219
16	YC50-1316	exhaust pipe heat spacer 50CC d6xd12x1.5mm	Joint embout silencieux 50CC d6xd12x1.5mm		5	50A1219

17	YC50-13-30	YCF50 Noise reducer (spark arrestor)	Bride de pot YCF50		1	50A1219
----	------------	--------------------------------------	--------------------	--	---	---------

**Seat & Plastic kit**

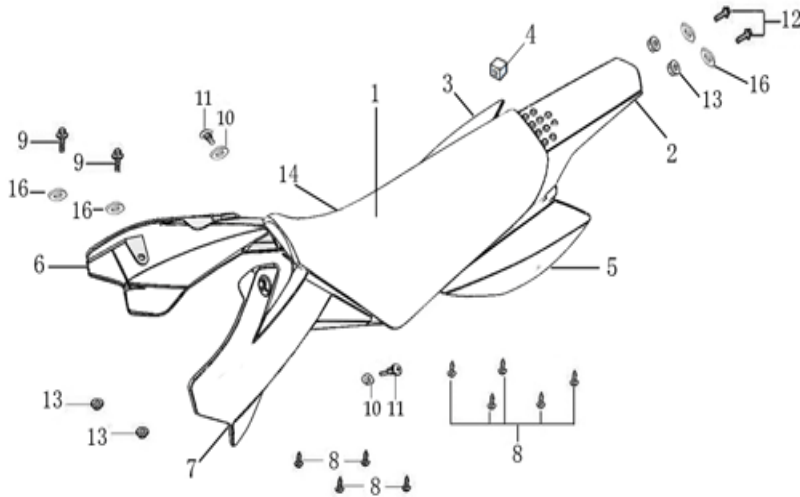

N°	Ref.	Description	Français	Picture	Qty/ Bike	Model
1	YC50-1401-05	YCF50 Seat assy L=405mm 2016	Selle YCF50 2016		1	50A1619/50E1619
2	YC50-14-012-WH	YCF50 Rear fender WHITE	Garde boue arrière YCF50 BLANC		1	5012/50A1519/50E1719
3	YC50-14-022-WH	YCF right side plastic WHITE	Plaque latérale droite YCF BLANCHE		1	50A1219/50E1719
4	YC110-14-03	Cushion for right side plastic	caoutchouc plaque laterale droite		1	ALL BIKES
5	YC50-14-042-WH	YCF50 Left side plastic WHITE	Plaque latérale gauche YCF50 BLANCHE		1	50A1219/50E1719
6	YC50-14-05-WH	YCF Right shroud WHITE 50CC	ouie radiateur droite YCF 50CC BLANC		1	5012/50A1719/50E17
7	YC50-14-06-WH	YCF50 Right shroud WHITE	Ouie radiateur droite YCF50 BLANCHE		1	5012/50A1718/50E17
8	GB845-ST4.8x16-G	Screw for plastic kit ST4.8x16	vis plastique ST4.8x16		9	ALL BIKES 1219 (BUT BIGY)
9	GB5787-M6x25-W	hex. Bolt with flanged M6x25	vis M6x25		1	ALL BIKES
9	GB5787-M6x20-W	hex. Bolt with flanged M6x20	vis M6x20		1	ALL BIKES
16	YC110-03-01	Rubber washer d6xd18x4mm	joint caoutchouc d6xd18x4mm		2	ALL BIKES 1519
16	GB96-d6	flat washer d6	rondelle d6		2	ALL BIKES 1519
13	GB6177-M6-W	Hex. Flanged nut M6	écrou M6		2	ALL BIKES 1519
11	FB5787-M5x12-W	hex. Bolt with flanged M5x12	vis M5x12		2	ALL BIKES 1219







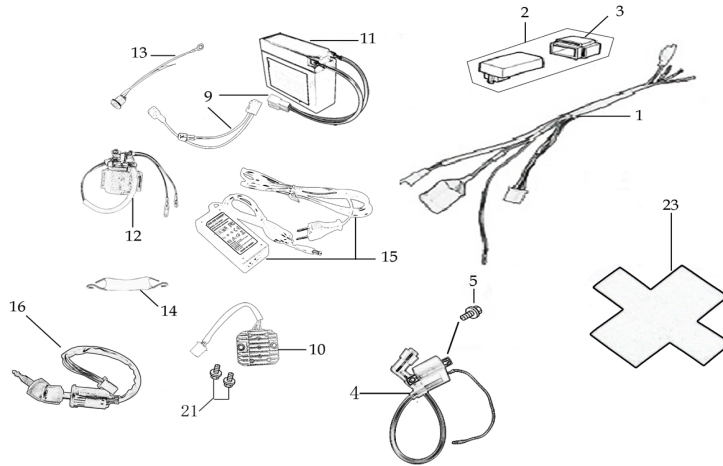

	YC110-02-13	Rubber washer d6xd14x3mm	joint caoutchouc d6xd14x3mm		2	ALL BIKES 1219
11	GB96-d5-W	flat washer d5xd12	rondelle d5xd12		2	ALL BIKES 1519
12	GB5787-M6x20-B	hex. Bolt with flanged M6x20 BLACK	vis M6x20 NOIR		2	ALL BIKES 1519
16	YC110-03-01	Rubber washer d6xd18x4mm	joint caoutchouc d6xd18x4mm		2	ALL BIKES 1519

## ELECTRIC





N°	Ref.	Description	Français	Picture	Qty/ Bike	Model
1	YC50-1501-01	Wire harness 50CC 2014	Faisceaux électrique 50CC 2014		1	50A1419
	YC50-1547-01	Fuse 50A d6x30mm F15AL250V			1	50A1419
2	YC50-1503	CDI Ignitor assy.50A	CDI 50A		1	50A1219
3	YC50-1509	Ignitor rubber small	caoutchouc cdi		1	50A1219
4	YC50-1504	Ignitor coil L=130mm	bobine haute tension L=130mm		1	50A1219
5	GB5787-M6x16-W	Hex. Bolt M6x16	vis m6x16		2	ALL BIKES 1219
9	YC50-1515	Battery cable RED	Cable pour Chargeur Batterie ROUGE		1	50A1319
9	YC50-1516	Battery cable BLACK	Cable pour Chargeur Batterie NOIR		1	50A1319
10	YC50-1502	rectifier for 50CC	Rectificateur		1	50A1219
21	GB5787-M6x10-W	Hex. Bolt M6x10	vis M6x10		2	50A1219/F88s1316/F88se16 19
11	YC50-1507-01	Battery 12V 2.3AH BT4B-BS 50CC 2015	Batterie 12V 2.3AH BT4B-BS 50CC 2015		1	50A1419

12	YC50-1510	relay 50CC	Relais démarreur 50CC		1	50A1219/F88se1519/F125se1519
13	YC50-1513	Charger connexion 50CC	Connection chargeur 50CC		1	50A1319
14	YC110-1508-01	Hustle rubber 2016	Maintien complet Batterie 2016		1	50A1719/F88se1619/F125se1619
16	YC110-0021-02	Key contactor Waterproof 2018	Contacteur a cle 2018		1	50A1819/50E1819/F88se1819/F125se1819
17	YC110-1531-04	Key contactor bracket YCF50A 2018	Support contacteur a cle YCF50A 2018		1	50A1819/50E1819/F88se1819/F125se1819
	YC110-1515-01	Rubber protection charge plug	Caoutchouc protection prise chargeur		1	50A1819
23	YC50-1523-01	Battery protection 50A 117x45x87mm	Protection Batterie 50A 117x45x87mm		1	50A1519

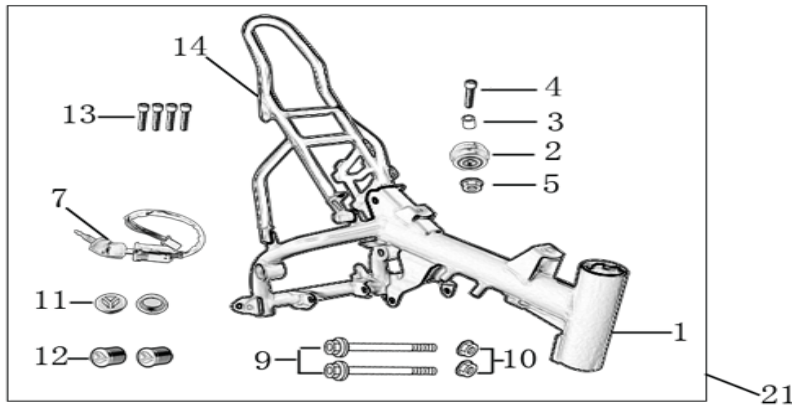
### Frame









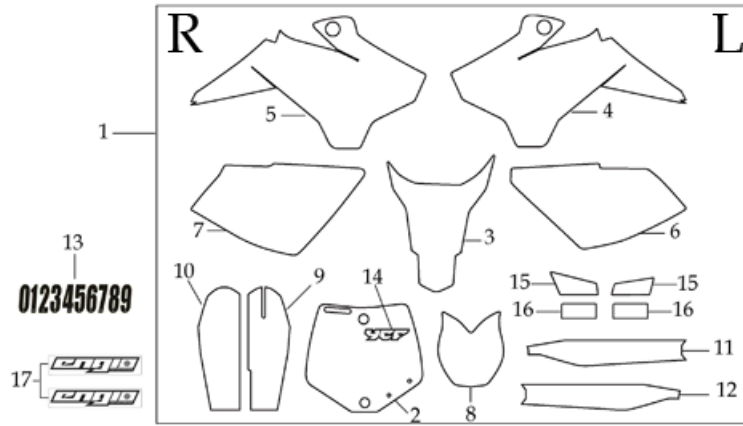



N°	Ref.	Description	Français	Picture	Qty/ Bike	Model
1	YC50-172-01-WH	YCF50 Frame 2014 WHITE +2°	Cadre YCF50 2014 BLANC +2°		1	50A1419
2	YC50-2201	YCF Chain tensioner component	roulette chaine YCF		1	50A1219/50E1619
	YC50-2201-01	bushing d10xd14x10mm	entretoise d10xd14x10mm		1	50A1219/50E1619
	GB70-M10x50x1.5W	Hex. Bolt M10x50	Vis M10x50		1	50A1219/50E1619
	GB6187-M10-1.5-W	Self-locking Nut M10	écrou M10		1	50A1219/50E1619
9	GB5787-M8x95-W	Hex. Bolt with flanger M8x95	vis M8x95		2	50A1319/50E1619
10	GB6187-M8-W	Self locking nut M8	ecrou M8		2	ALL BIKES
11	YC50-1210	Rubber cover (swing arm axle)	Capuchon cadre (axe bras)		2	50A1219/50E1619
11	YC50-1211	Rubber cover (bottom of frame) 50CC	Capuchon cadre (dessous cadre) 50CC		2	50A1219/50E1619
12	GB70-M8x16	Hex. Bolt M8X16	vis M8x16		4	50A1219/50E1619

14	YC50-16-02-BK	YCF50 Rear frame part Chromolly 2014 BLACK	Boucle arriere YCF50 Chromolly 2014 NOIRE		1	50A1419
21	YC50-1621-01-WH	complète frame YCF50 2014 WHITE(with YC50-1211 2EA)	cadre complet YCF50 2014 BLANC		1	50A1419

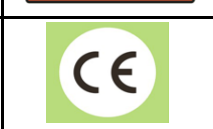
**GRAPHICS**







N°	Ref.	Description	Français	Picture	Qty/ Bike	Model
1	KD50A2019	YCF50 complete graphic kit 2019	Kit deco complet YCF50 2019		1	50A19
	YC110-1901	Sticker Chain	Autocollant Chaîne		1	ALL BIKES 1319
	YC110-1902	Sticker Tire	Autocollant Pression Pneu		1	ALL BIKES 1319
	YC110-1903	Sticker Warning OIL Level	Autocollant Attention Niveau Huile		1	ALL BIKES 1319
	YC50-1904	Sticker Rear Mudguard 50A 70x57mm	Autocollant garde boue arriere 50A 70x57mm		1	50A1619
	YC50-1904-01	Sticker Rear Mudguard 50A Charging 65x34mm			1	50A1619/F88se1619/F1 25se1619
	YC110-1905	Sticker CE	Autocollant CE		1	ALL BIKES 1319
	YC110-1906	Warning sticker	Sticker Attention		1	ALL BIKES 1319
	YC110-1907	Warning Sticker Transport	Sticker Caisse Avertissement Transport		1	ALL BIKES 1319
	YC110-1908	Warning Sticker Shok Absorber	Sticker Avertissement Amortisseur		1	ALL BIKES 1319

**ENGINES**

	MOTEUR50-01-GY	Engine 50cc 2013	Moteur 50cc 2013		1	50A1319
	17311-1	Inlet Pipe,Pro 50cc 2012	PIPE ADMISSION 50cc 2012		1	50A1319
	GB5787-M6x20-W	Hex. Bolt M6x20	vis m6x20		2	ALL BIKES
	YC50-20-29	carburettor paper gasket	joint papier carburateur		1	50A1319
	YC50-20-25	intake pipe paper gasket	joint papier admission		2	50A1319
	YC50-20-26	intake pipe isolating gasket	joint plastique admission		1	50A1319
	YC50-20-93-GY	magneto crankcase 50CC 2013 GREY	carter d'allumage GRISE		1	50A1319
	YC50-20-87-GY	right crankcase cover GREY	carter moteur gauche GRISE		1	50A1319
	YC50-20-97	sprocket cover	protection PSB		1	50A1319/50E1619
	GB5787-M5x25-W	Flanged head bolt M5x25	Vis M5x25		3	50A1319
	420H/10T	Sprocket(10T)	PSB 10 DTS		1	50A1319
<b>CARBU</b>						
	YC50-20-31	Carburetor 5012 with main jet 50	Carburateur 5012 GICLEUR 50		1	50A1319
	GICLEUR50-02	main jet 50	GICLEUR 50		1	50A1319
	GB5787-M6x20-W	Hex. Bolt M6x20	vis m6x20		2	50A1319
<b>CARTONS - CAISSES MOTOS</b>						
	YC110-CARTON-50	BIKE BOX 50 YCF 1280x380x840mm	CARTON EMBALLAGE MOTO 50 1280x380x840mm		1	50A1219/50E1619
	YC110-FOAMBOX	Foam box 2014 420x340x160mm	Cale PS		1	ALL BKIES 1419
	YC110-FILM	Protective film for seat 600x600x0.02mm	Protection plastique Selle		1	ALL BKIES 1419
	YC110-2101-03	Silicagel	Silicagel		5	ALL BIKES

## CATALOGUES - FICHES MOTOS - FICHES STICKER

	YC110-0700-01	Accessory tools	Trousse a outils		1	ALL BIKES 1319
	YC110-0700-0201	Owner manual 2015	Manuel Utilisation 2015		1	ALL BIKES 1319
	YC110-0700-0401	Vin Plate 2015	Plaque Vin 2015		1	ALL BIKES 1319
	YC110-0700-03	A4 sheet assy	Fiche A4		1	ALL BIKES 1319

