



YCF-Riding.com

**FACTORY SP3190**  
**DAYTONA**



Handle bar assembly

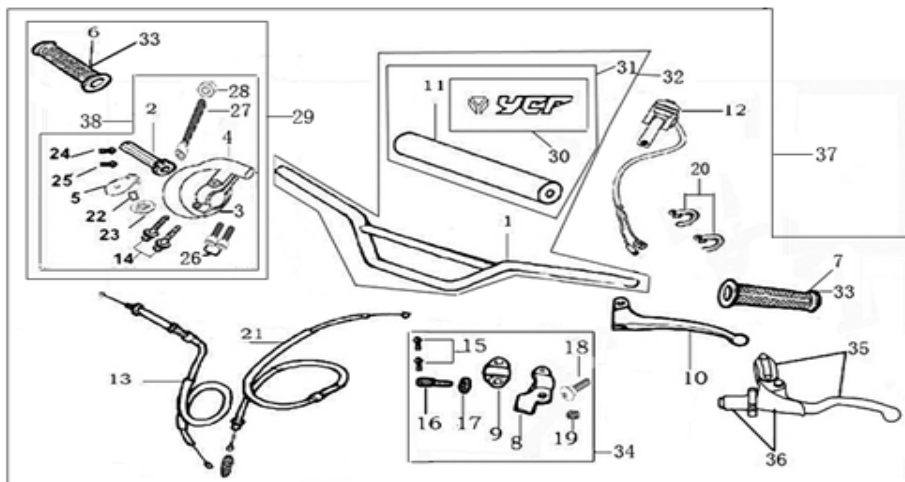

N°	Ref.	Description	Français	Qty/ Bike	MODEL
1	YC110-0101-13-BK	Aluminium Handle Bar, TWIN ALL L=760mm 2016 BLACK	Guidon aluminium BAS TWIN ALL L=760mm 2016 NOIR	1	SP316
2	YC110-01021-01	YCF Throttle Body 2012 BLACK	plastique poignée de gaz YCF 2012 NOIR	1	ALL BIKES 2012-2016
3	YC110-01021-05	Lower Throttle Body Housing 2014	dessous poignée gaz 2014	1	P15014-16/SM15014-16/SP114-16/SP214-16/SP314-16
4	YC110-01021-03	Upper Throttle Body Housing YCF 2012	dessus poignée gaz YCF 2012	1	ALL BIKES 2012-2016
5	YC110-01021-02	Upper Throttle Body Housing Cover YCF 2012	plastique du dessus poignée gaz YCF 2012	1	ALL BIKES 2012-2016
6	YC110-01-01-GY	YCF Right Grip GREY	poignée caoutchouc droite YCF GRISE	1	ALL BIKES2012-2016
7	YC110-01-02-GY	YCF Left Grip GREY	poignée caoutchouc gauche YCF GRISE	1	ALL BIKES2012-2016
8	YC110-0108-05	Clutch upper bracket 2014 SILVER	cocotte basse embrayage 2014 SILVER	1	F12514-16/P12514-16/P15014-16/SM15014-16/SP114-16/SP214-16/SP314-16
9	YC110-0109-05	Clutch lower bracket 2014 SILVER	demi cocotte embrayage 2014 SILVER	1	F12514-16/P12514-16/P15014-16/SM15014-16/SP114-16/SP214-16/SP314-16

	FB13-8×10×8-Cu	Clutch lever bushing $\Phi 8 \times \Phi 10 \times 8.1$ mm copper	entretoise levier embrayage $\Phi 8 \times \Phi 10 \times 8.1$ mm	1	F12514-16/P12514-16/P15014-16/SM15014-16/SP114-16/SP214-16/SP314-16
10	YC110-0103-03	Clutch lever 2014 (with FB13- $\Phi 8 \times \Phi 10 \times 6$ -Cu 1EA+FB13- $\Phi 8 \times \Phi 10 \times 8$ -Cu 1EA)	levier embrayage 2014	1	RS12/RSP12/SM15012/C12/CP12/F12513-16/P12513-16/P15013-16/SM15013-16/SP113-16/SP213-16/SP314-16
11	YC110-0116	Bar pad for Aluminium Handlebar with Bar L=195mm	Mousse guidon pour guidon alu avec barre L=195mm	1	SM15013-16/SP113-16/SP213-16/SP313-16
12	YC110-0105-04	Kill Switch ON/OFF daytona ANIMA engine L=580MM	Coupe circuit on off pour daytona ANIMA L=580MM	1	FP12/SP313-16
13	YC110-0106	Throttle Cable L=840mm A+B=125	Cable gaz L=840mm A+B=125	1	ALL BIKES2012-2016(BUT50/F88s/F88se)
14	GB5787-M6×22-G	Hex. Bolt with Flanged Face M6X22	vis M6X22	2	ALL BIKES2012-16(BUT50A)
15	GB5787-M6×20-G	Hex. Bolt with Flanged Face M6X20	vis M6X20	2	F12512-16/P12514-16/P15014-16/SM15012-16/SP112-16/SP212-16/SP312-16
16	YC110-0103-04	Clutch Adjust bolt M7×18mm	Tendeur cocotte embrayage M7×18mm	1	F12512-16/P12513-16/P15013-16/SM15013-16/SP113-16/SP213-16/SP313-16
17	YC110-0117	Clutch Tight Nut M7	ecrou cocotte embrayage M7	1	F12512-16/P12513-16/P15013-16/SM15013-16/SP113-16/SP213-16/SP313-16
18	27-06022B	Clutch Stepped bolt M6X22	vis cloche embrayage M6X22	1	F12512-16/P12513-16/P15013-16/SM15013-16/SP113-16/SP213-16/SP313-16
19	6183-06000B	Clutch Self-lock Nut M6	ecrou cloche embrayage M6	1	F12512-16/P12513-16/P15013-16/SM15013-16/SP113-16/SP213-16/SP313-16
20	YC110-01-03-BK	Tape 150mm BLACK	colier maintien cable 150mm NOIR	2	ALL BIKES
20	YC110-01-03-WH	Tape 150mm WHITE	colier maintien cable 150mm BLANC	2	ALL BIKES
20	YC110-01-05-BK	Tape 350mm BLACK	colier maintien cable 350mm NOIR	5	ALL BIKES
20	YC110-01-05-WH	Tape 350mm WHITE	colier maintien cable 350mm BLANC	1	AFTER MARKET
21	YC110-0107-09	Clutch Cable Assy. L=900mm A+B=83mm	cable embrayage L=900mm A+B=83mm	1	SP314-16
22	YC110-0102-08	YCF Throttle cable Bearing $\Phi 8 \times \Phi 16 \times 5$ mm	Roulement poignee gas YCF $\Phi 8 \times \Phi 16 \times 5$ mm	1	ALL BIKES2012-2016
23	YC110-0102-07	YCF Throttle cable guide pulley plastic $\Phi 12 \times \Phi 16 \times \Phi 28 \times 8$ mm	Roulette plastique Poignee Gas YCF $\Phi 12 \times \Phi 16 \times \Phi 28 \times 8$ mm	1	ALL BIKES2012-2016
24	GB819-M4×12	Plus screw M4×12	vis M4×12	1	ALL BIKES2012-2016
25	GB819-M4×20	Plus screw M4×20	vis M4×20	1	ALL BIKES2012-2016

26	GB70-M6×20-B	Hex. Bolt M6x20 BLACK	vis M6x20 NOIR	2	ALL BIKES2012-2016
27	GB70-M5×12	Hex. Bolt M5×12	vis M5×12	1	ALL BIKES2012-2016(BUT50A)
30	YC110-012027-BK	RUBBER for Bar Pad suitable Aluminium Handlebar with Bar 185mm×178mm 2016 BLACK	CAOUTCHOUC mousse guidon Aluminium avec Barre 185mm×178mm 2016 NOIR	1	SP316
31	YC110-0133-01BK	Complete Bar Pad for Aluminium Handlebar with Bar L=195mm 2016 BLACK	Mousse guidon complete pour guidon Aluminium avec Barre L=195mm 2016 NOIR	1	SP316
32	GASB-02BK	Aluminium handle bar ( with black pad and pvc ) TWIN ALL BLACK 2016	Guidon aluminium BAS TWIN ALL L=740mm 2016 NOIR	1	SP316
33	PPC010-GY	YCF set of grip GREY	Paire de poignée caoutchouc YCF GRISE	1	ALL BIKES2012-2016
34	YC110-0126-01	Clutch bracket Assy. 2014 SILVER	Cocotte embrayage complete 2014 SILVER	1	F12514-16/P12514-16/P15014-16/SM15014-16/SP114-16/SP214-16/SP314-16
35	YC110-0134-02	Cnc adjustable bracket with lever 2014 SILVER	Cocotte CNC réglage rapide avec levier embrayage 2014 SILVER	1	F12514-16/P12514-16/P15014-16/SM15014-16/SP114-16/SP214-16/SP314-16
36	YC110-0103-10	rubber on clutch lever	caoutchouc levier embrayage	1	F12514-16/P12514-16/P15014-16/SM15014-16/SP114-16/SP214-16/SP314-16
38	YC110-01022-N	YCF Throttle Assy. 2014 without grip (with YC110-0102-08 1EA)	Poignée gaz réglable YCF 2014 nue	1	P15014-16/SM15014-16/SP114-16/SP214-16/SP314-16

#### Steering stem assembly

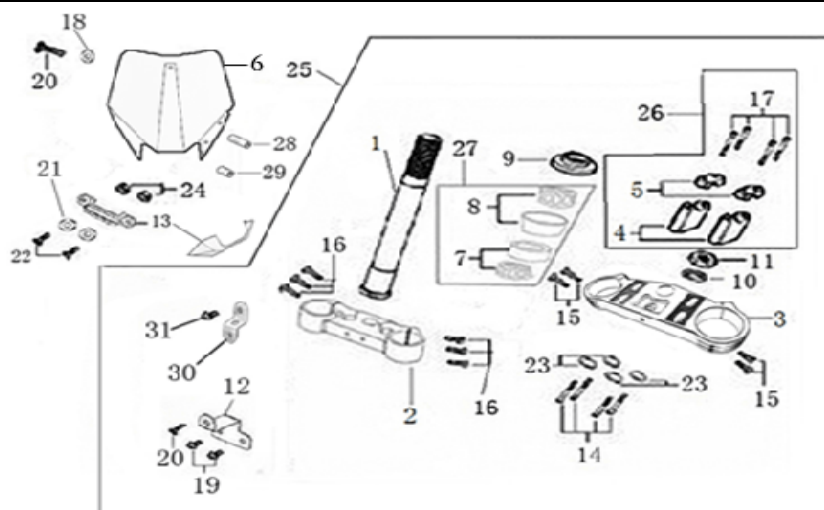

N	Ref.	Description	Français	Qty/ Bike	MODEL
1	YC110-0201-03	Steering stem 233 mm	tige colonne direction 233 mm	1	ALL BIKES2012-16(BUT50A/F88s/F88se)

2	YC110-0202-41-BK	Lower triple clamp 160 mm $\phi$ 48mm 2014 BLACK	té fourche inférieur 160 mm $\phi$ 48mm NOIR	1	SP31516
3	YC110-0201-42-BK	Top Triple Clamp 160 mm $\phi$ 48 mm (for Engi fork) 2014 BLACK	té fourche supérieur 160mm $\phi$ 48mm (pour fourche Engi) NOIR	1	SP31516
5	YC110-0202-03	Top bar mount CNC $\Phi$ 28.6mm/height 18mm BLACK	Pontet guidon supérieur $\Phi$ 28.6mm NOIR	2	FP09/SP316
4	YC110-0203-29	Lower Bar Mount CNC START type, not adjustable $\phi$ 28.6 / height 55 mm BLACK	Pontet guidon inférieur non ajustable type START $\phi$ 28.6 / hauteur 55mm NOIR	2	SP316
	YC110-0222-02	Lower Bar Mount Heightening block CNC 20mm adjustable	Cale 20 mm	2	SP316
6	YC110-0212-07RD	Front Number Plate 2014 RED	PLAQUE AVANT 2014 ROUGE	1	SM14/F125s1516/SPI II15015/SM15016/SP 319016
7	297-46/23.5	Lower Taper roller bearing 46/23.5	roulement inférieur 46/23.5	1	ALL BIKES2012- 16(BUT50A/F88s/F88se)
8	297-46/22	Top Taper roller bearing 46/22	roulement supérieur 46/22	1	ALL BIKES2012- 16(BUT50A/F88s/F88se)
9	YC110-02-09	Top nut for steering $\phi$ 52	écrou crantellé colonne direction $\phi$ 52	1	ALL BIKES2012-2016
10	YC110-02-10	Washer for steering stem nut $\Phi$ 22.5 $\times$ $\Phi$ 36 $\times$ 0.7	joint colonne direction $\Phi$ 22.5 $\times$ $\Phi$ 36 $\times$ 0.7	3	ALL BIKES2012-2016
11	YC110-02-11	Nut for steering stem M22	écrou supérieur colnne direction M22	1	ALL BIKES2012-2016
13	YC110-0214-01-WH	Break Line Retainer 2014 White (with GB9074.5-M4 $\times$ 10-W 1EA )	guide durite sur plaque avant 2014 Blanc	1	ALL BIKES2014- 2016(BUT50A/F88s/F88se /F88s)
14	GB70-M8 $\times$ 30	Stud screw M8X30	vis M8X30	4	ALL BIKES2012- 16 (BUT50A)
15	GB70-M6 $\times$ 25	Stud screw M6X25	vis M6X25	4	ALL BIKES2012- 16 (BUT50A)
16	GB70-M6 $\times$ 20	Stud screw M6X20	vis M6X20	6	ALL BIKES2013- 16(BUT50A)
17	GB70-M8 $\times$ 25	Stud screw M8X25	vis M8X25	4	ALL BIKES2012- 16 (BUT50A)
18	GB97- $\Phi$ 6-W	flat washer $\phi$ 6	rondelle $\phi$ 6	1	ALL BIKES2012-16
19	GB5787-M6 $\times$ 16-W	Hex. Bolt with Flanged Face M6X16	vis M6X16	2	ALL BIKES2012-2016
20	GB9074.5-M6 $\times$ 12-W	Plus screw M6X12 (for bottom front No plate)	vis m6x12 bas plaque No avant	1	ALL BIKES2014- 2016(BUT50A/F88s/F88se /F88s)

21	GB97-Φ4-W	flat washer φ4	rondelle φ4	1	ALL BIKES2012-16
22	GB818-M4×10-W	Plus screw M4×10	vis M4×10	1	ALL BIKES2012-16
23	GB93-Φ8-W	Spring washer Φ8mm	rondelle Φ8mm	4	ALL BIKES2012-2016
25	YC110-02-044-BK	Complete Triple Clamp (TOP48 / BOTTOM 48) adjustable bar mount SPIII150 2014 BLACK	Te Fourche Complet (TE SUP. 48 / TE INF.48) pontet ajustable SPIII150 2014 NOIR	1	SP31516
26	YC110-0203-08	Set of Bar mount φ28.5mm / height 75mm (with GB70-M8×25 4EA+GB70-M8×50 4EA+GB93-Φ8-W 4EA)	jeu pontet guidon φ28.5mm / hauteur 75 mm	1	SP316
27	KRDIRECTION46	set of bearing for steering 46/23.5、46/22	kit rlt colonne direction 46/23.5、46/22	1	ALL BIKES2012-16(BUT50CC/F88s/F88se)
30	YC110-0213-08	Number plate bracket 2014	support plaque avant 2014	1	ALL BIKES2014-2016(BUT50A/F88s/F88se /F88s)
31	GB5787-M6×16-W	Hex. Bolt M6X16	vis M6×16	1	ALL BIKES2014-2016(BUT50A/F88s/F88se /F88s)
32	YC110-02-20	Washer for steering stem nut	joint colonne direction	1	ALL BIKES2015-2016 (But50A/F88s/F88se)

#### Front Fender

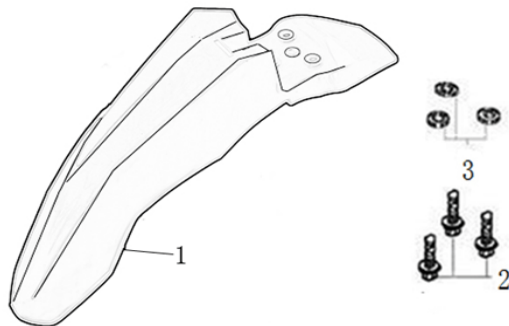

N	Ref.	Description	Français	Qty / Bike	MODEL
1	YC110-032-01RD	YCF Front Fender 2014 RED	GARDE BOUE AVANT 2014 ROUGE	1	F125s1516/SP315015/SM15016/SP319016
2	GB5787-M6×20-W	Hex. Bolt with flanged M6X20	vis M6X20	3	ALL BIKES
	GB96-Φ6-W	Washer φ6×φ18mm	Rondelle φ6×φ18mm	3	ALL BIKES
3	YC110-03-01	Rubber washer Φ6×Φ18×4mm	caoutchouc Φ6×Φ18×4mm	3	ALL BIKES

#### Front & Rear absorber

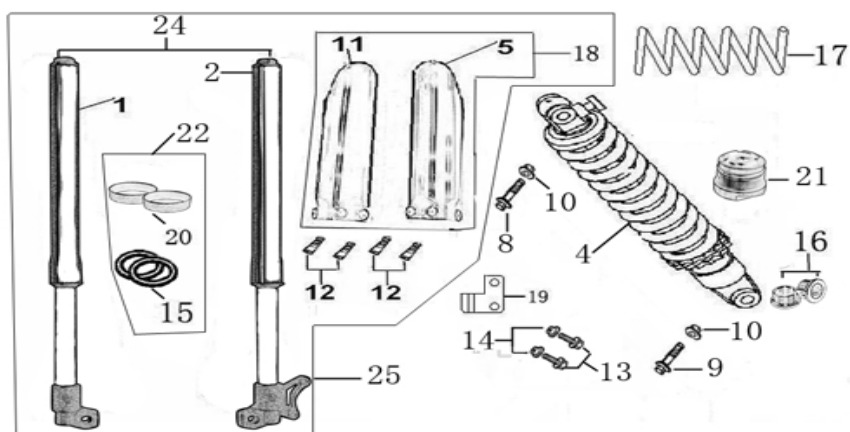

N	Ref.	Description	Français	Qty/ Bike	MODEL
1	YC110-0401-21	Front right fork ENGI 800mm (adjustable) TITAN	tube fourche droit 800mm TITANE	1	SP316
2	YC110-0402-21	Front left fork ENGI 800mm (adjustable) TITAN	Tube fourche gauche 800mm TITANE	1	SP316
4	YC110-0404-63	Shock absorber ENGI L=335mm 2016	Amortisseur ENGI L=335mm 2016	1	SP316
5	YC110-04-015-BK	YCF Left front fork protection 735mm BLACK	Protection fourche YCF gauche 735 mm NOIR	1	P12516/P15016/SM15016/SP116/SP216/SP316
8	GB5787-M12×45-W	Hex. Bolt with flanged M12X45	vis M12X45	1	P88s13-16/P12513-16/P15013-16/SM15013-16/SP113-16/SP213-16/SP313-16
9	GB5787-M12×60-W	Hex. Bolt with flanged M12×60	vis M12×60	1	SP113-16/SP213-16/SP313-16
10	GB6187-M12-W	Self-locking Nut M12	écrou M12	2	ALL BIKES2012-2016(BUT50A)
11	YC110-04-024-BK	YCF Right front fork protection 735 mm BLACK	Protection fourche droite YCF 735 mm NOIR	1	P12516/P15016/SM15016/SP116/SP216/SP316
12	GB5787-M6×12-W	Plus screw M6X12	vis M6X12	4	P88s13-15/P12513-16/P15013-16/SP113-16/SP213-16/SP313-16/SM15013-16
13	GB5787-M6×16-W	Plus screw M6X16	vis M6X16	2	ALL BIKES2013-16(BUT50A)
14	GB6170-M6-W	Nut M6	ecrou M6	2	P12516/P15016/SP116/SP216/SP316/SM15016
16	YC110-0419-03	shock bottom spacer ENGI Φ12Φ14×6×11mm	entretoise amortisseur pour bras mono ENGI Φ12Φ14×6×11mm	4	SP316
18	PFYCF12-BK	YCF set of fork protection 735mm 2012 black	jeu protection fourche YCF noir	1	P12516/P15016/SM15016/SP116/SP216/SP316
19	YC110-0403-05	oil steel line retainer on left front fork 2016	passse durite sur protection fourche gauche 2016	1	P12516/P15016/SP116/SP216/SP316/SM15016
24	ENGI1-800	Pair of fork ENGI 800mm (Adjustable) TITAN	Jeu de fourche 800mm ENGI TITANE	1	SP316

Front Brake Assy

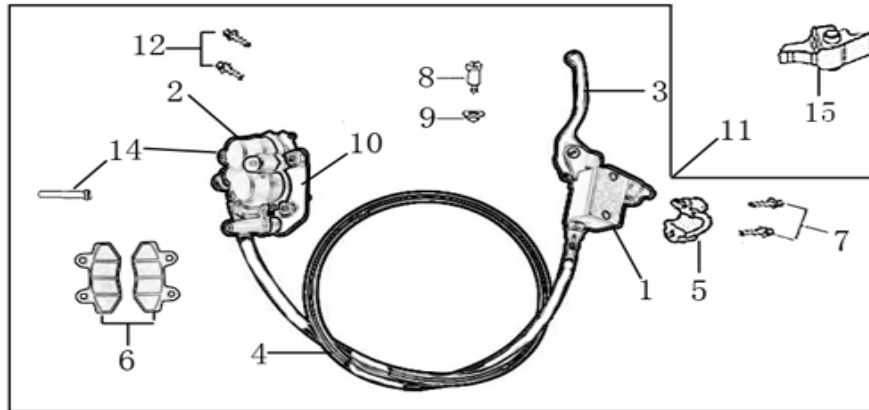

N	Ref.	Description	Français	Qty/ Bike	MODEL
1	YC110-0501-0104	Front Brake Reservoir for 2 pump $\Phi$ 10 2016	maitre cylindre frein avant pour étrier 2 pistons $\Phi$ 10 2016	1	P12516/P15016/SP116/SP216/SP316/SM15016
2	YC110-0501-0207	Front Brake caliper for 2 pump w/t abestos $\Phi$ 10 2016	étrier frein avant double pistons sans amiante $\Phi$ 10 2016	1	SP216 / SP316
3	YC110-0501-017	Front brake lever for 2 pump brake 2016	levier frein pour frein double pistons 2016	1	SP216 / SP316
4	YC110-0501-0319	Front brake steel line L=1170mm $\Phi$ 10/ $\Phi$ 10 BLACK 2016	durite frein avant L=1170mm $\Phi$ 10/ $\Phi$ 10 NOIR 2016	1	SP316
5	YC110-0501-022	Brake perch bracket for double pump	demi cocotte frein avant pour frein double pistons	1	ALL BIKES2012-16(BUT50A)
6	YC110-0501-0416	Front Brake pads for double pump brake with copper substrate 2016	jeu plaquette frein avant pour frein 2 pistons SANS AMIANTE 2016	2	SP216/SP316
7	GB5787-M6×22-G	Hex.bolt with flanged M6X22	vis M6X22	2	ALL BIKES2012-16(BUT50A)
8	HB06-M6×25-G	Hex.bolt with flanged M6X25	vis M6X25	1	ALL BIKES2012-16(BUT50A)
9	GB6177-M6-G	Self-locking nut M6	écrou M6	1	ALL BIKES2012-16(BUT50A)
10	YC110-0501-037	Bracket for front brake SP2/SP3 2016	patte frein avant etrier SP2/SP3 2016	1	SP216 / SP316
11	YC110-0501-31	front brake assy 2 pumps L=1170mm $\Phi$ 10/10 w/t abestos 2016	kit frein avant 2 pistons avec gaine plastic noire L=1170mm $\Phi$ 10/10 sans amiante	1	SP316
12	GB70-M6×30-W	Stud screw M6X30	vis M6X30	2	ALL BIKES2012-16 (BUT50A)
14	YC110-0555-01	caliper screw for front brake L=55mm Army green	vis plaquette frein avant L=55mm	1	SP216/SP316

Front Wheel Assy

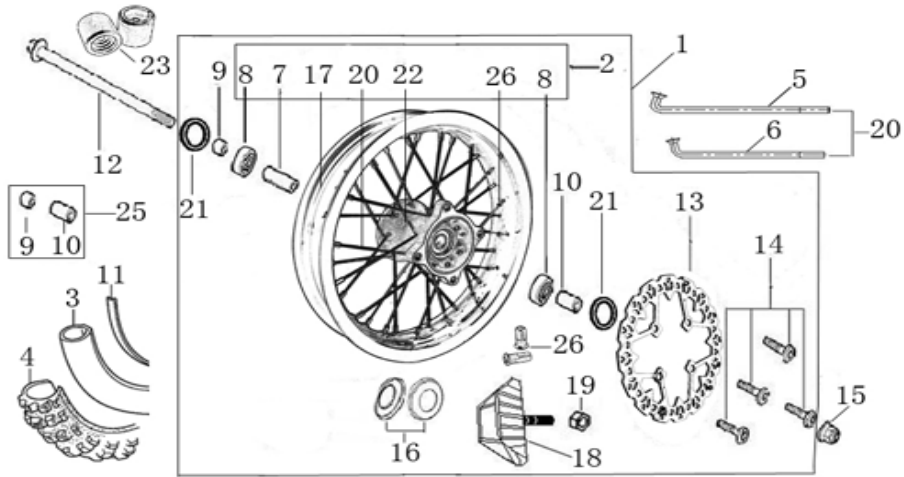

N	Ref.	Description	Français	Qty/ Bike	MODEL
1	YC110-0601-5C-BK	Complete ALUMINIUM Front wheel 1.4x14' with disk CNC hub BLACK / BLACK Rim	Roue avant complète ALUMINIUM 1.4x14' avec disque moyeux CNC BLACK / Jante NOIRE	1	SP316
2	YC110-0602-5C-BK	Complete ALUMINIUM Front wheel 1.4x14' without disk CNC hub BLACK / BLACK Rim 2016	roue avant complète ALUMINIUM 1.4x14' sans disque moyeux CNC NOIR / Jante NOIRE 2016	1	SP316
3	CHAMBRE14	Tube for front tire 60/100-14' GL	chambre air 14' GL	1	F12512-16/F125s12-16/F125se1516/P12513-16/P15013-16/SP113-16/SP213-16/SP313-16
	FB6170-M8-Cr	Tire valve nut M8	Ecrou M8 pour chambre a air	1	ALL BIKES
4	60/100/14ARRO	Front tyre 60/100/14 ARRO 2015	pneu avant 60/100/14 ARRO 2015	1	SP216/SP316
7	YC110-0607-03	Front axle bushing $\phi 17 \times \Phi 25 \times 46$	entretoise central roue avant $\phi 17 \times \Phi 25 \times 46$	1	SP216/SP316
8	96140-6003-ZZ	Ball bearing 6003 $\Phi 35 \Phi 17 \times 10$	roulement roue 6003 $\Phi 35 \Phi 17 \times 10$	2	SP216/SP316
9	YC110-06-048	Front wheel spacer right $\phi 15 \times \Phi 22 \times 37.5 \text{mm}$ with STEP 2016	entretoise roue avant droite $\phi 15 \times \Phi 22 \times 37.5 \text{mm}$	1	SP216/SP316
10	YC110-06-056	Front wheel spacer left $\phi 15 \times \Phi 22 \times 47 \text{mm}$ with STEP 2016	entretoise roue avant gauche $\phi 15 \times \Phi 22 \times 47 \text{mm}$	1	SP216/SP316
11	YC110-06-01	tire lining for 1.4x14'	fond jante av 14'	1	F12512-16/F125s12-16/F125se1516/P12513-16/P15013-16/SP112-16/SP212-16/SP312-16
12	YC110-06-061	Front Axle 215 mm with Self-locking nut M14 for Marzocchi style fork	axe de roue avant L=215 mm marzocchi avec ecrou M14	1	ALLBIKES2013-16(BUT50A/SM)



13	YC110-0513-02	Front disk $\varnothing$ 220 mm 2016	disque frein avant $\varnothing$ 220 mm 2016	1	ALL BIKES 2016(BUT50A/F88s/F88se)
14	GB70.2-M8 $\times$ 16	Screw for disk M8X16	vis disque frein M8X16	4	ALL BIKES2016 (BUT50A)
15	GB6187-M14-W	Self-locking nut M14	écrou roue avant M14	1	ALL BIKES2012-16(BUT50A)
17	YC110-0601-012BK	ALUMINIUM 7116 Rim for Front wheel 1.4 $\times$ 14' 7116 Black	cerceau roue av 1,4 $\times$ 14' ALUMINIUM 7116 Noir	1	SP212-16/SP312-16
18	GRIPSTER1.40	Gripster 1.40	gripster 1,40	1	SP112-16/SP212-16/SP312-16
19	GB6170-M8-W	Nut M8	ecrou M8	1	SP112-16/SP212-16/SP312-16
20	JR14-14.5	set of front spoke 14' (147mm $\times$ 32)	Jeu rayon avant 14' (147mm $\times$ 32)	1	F12512-16/F125s12-16/F125se1516/P12512-16/P15013-16/SP112-16/SP212-16/SP312-16
21	YC110-0611	OIL SEAL $\varnothing$ 22 $\times$ 35 $\times$ 5	joint spy roue $\varnothing$ 22 $\times$ 35 $\times$ 5	2	ALL BIKES2013-16(BUT50A)
22	YC110-0622-04-BK	YCF Front hub CNC BLACK 2016	YCF Moyeux avant CNC NOIR 2016	1	SP316

#### Fuel Tank

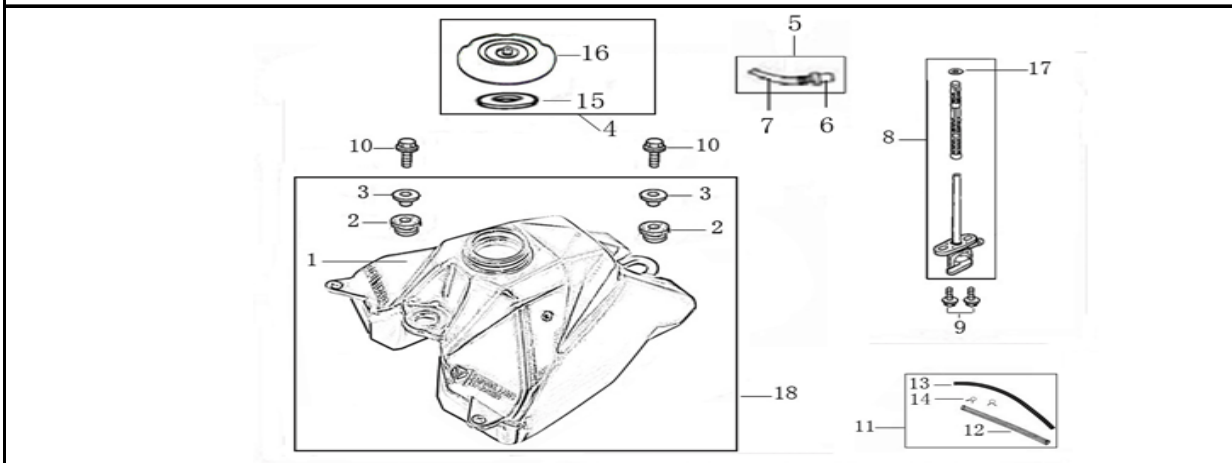

N	Ref.	Description	Français	Qty/ Bike	MODEL
1	YC110-0701-01	YCF Fuel tank with YC110-1910 1EA (suitable for pre 2013 bikes)	Reservoir YCF (Adaptable pour motos avant 2013)	1	ALL BIKES2013-16 (BUT50A)
2	YC110-07-01	Cushion for fuel tank	caoutchouc pour reservoir	2	ALL BIKES2011-16
3	YC110-07-02	Washer for fuel tank $\Phi$ 12 $\times$ $\Phi$ 30 $\times$ 11mm	entretoise pour reservoir $\Phi$ 12 $\times$ $\Phi$ 30 $\times$ 11mm	2	ALL BIKES2011-16

4	YC110-0702-01	YCF Tank cap plastic 2013	Bouchon reservoir plastique YCF 2013	1	ALL BIKES2013-16
5	YC125-0704-BK	Fuel tank valve BLACK	Valve prise air NOIR	1	ALL BIKES
6	YC110-0704-BK	Cap of Fuel tank valve BLACK	Capuchon Valve prise air NOIR	1	ALL BIKES
7	YC110-0705-BK	Fuel tank valve Hose L=40mm BLACK	Durite caoutchouc Vale prise air L=40mm NOIRE	1	ALL BIKES
8	YC110-0703	Fuel cock assy.	robinet essence	1	ALL BIKES
9	GB5787-M6×16-W	Hex. Bolt with flanged M6X16	vis M6X16	2	ALL BIKES2012-2016
10	GB5787-M8×30-B	screw M8X30 BLACK	vis M8x30 NOIR	2	P88s13-15/P12513-16/P15013-16/SM15013-16/SP113-16/SP213-16/SP313-16
11	YC110-0706	fuel tank rubber line + spring Φ4.5×Φ8.5×210mm	durite reservoir avec ressort Φ4.5×Φ8.5×210mm	1	ALL BIKES
12	YC110-07061	fuel tank lspring L=180mm	ressort durite reservoir L=180mm	1	ALL BIKES
13	YC110-07062	fuel tank rubber line Φ4.5×Φ8.5×210	durite reservoir Φ4.5×Φ8.5×210	1	ALL BIKES
14	YC110-07063	Holding ring	collier FILTRE	2	ALL BIKES
15	YC110-0720-02	Rubber mat for tank cap plastic Φ14×Φ52×2mm Oil proof	Caoutchouc bouchon reservoir YCF Φ14×Φ52×2mm	1	ALL BIKES2013-16
17	YC110-0717	O-RING,Φ11×3mm For Fuel tank	Joint Thorique Φ11×3mm pour Reservoir	1	ALL BIKES2013-16 (BUT50A)
18	YC110-0718	YCF Complete fuel tank suitable for pre 2013 bikes (with YC110-07-01 2EA+YC110-07-02 2EA+YC110-1910 1EA)	Reservoir complet YCF 2013 (Adaptable pour motos avant 2013)	1	ALL BIKES2013-16 (BUT50A)

#### Air Filter

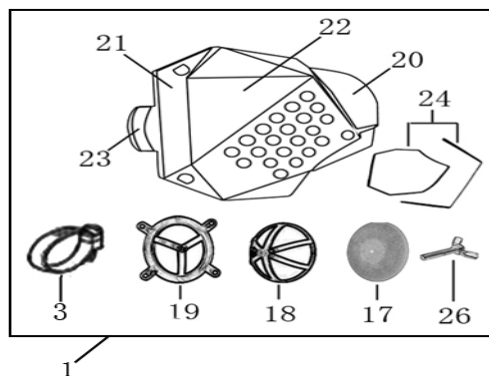

N	Ref.	Description	Français	Qty/ Bike	MODEL
---	------	-------------	----------	--------------	-------

1	YC110-08-02	Air box assy 2013 with YCF LOGO	Boite a air complete YCF 2013	1	SP113-16/SP213-16/SP315013-16
3	YC110-0805	Holding ring $\phi 27-\phi 51\text{mm}$	collier Filtre $\phi 27-\phi 51\text{mm}$	1	ALL BIKES2012-2016 (BUT50A)
17	YC110-08-011	YCF Air filter Foam	Mousse filtre a air YCF	1	P12516/P15016/SP112-16/SP212-16/SP312-16/SM15016
18	YC110-08-012	Top support for YCF air filter foam	support exterieur pour mousse filtre a air YCF	1	P1251516/P1501516/SM1501516/SP112-16/SP212-16/SP312-16
19	YC110-08-013	Inside support for YCF air filter foam	support interieur pour mousse filtre a air YCF	1	P1251516/P1501516/SM1501516/SP112-16/SP212-16/SP312-16
20	YC110-0820-01	Rear part of YCF air box 2015	Boitie arriere boite a air YCF 2015	1	SP11516/SP21516/SP31516
21	YC110-08-015	Front case of YCF air box	Boitie avant boite a air YCF	1	SP112-16/SP212-16/SP312-16
22	YC110-08-026	Cover with logo of YCF air box 2013	Couvercle cote boite a air YCF avec logo 2013	1	SP113-16/SP213-16/SP313-16
23	YC110-08-0171	Air box Rubber connexion $\phi 49\text{mm}$ for Kehin 28 carb(with YC110-0805 1EA)	Manchon boite a air $\phi 49\text{mm}$ pour carbu Kehin PE28	1	SP316
24	YC110-08-019	Cover Rubber Gasket of YCF air box	Joint Caoutchouc pour couvercle cote pour boite a air YCF	1	SP113-16/SP213-16/SP313-16
24	YC110-08-020	Rubber Gasket for Rear part / front part of YCF air box	Joint Caoutchouc pour Boitie avant / Boitie arriere pour boite a air YCF	1	SP113-16/SP213-16/SP313-16
24	YC110-08-021	Kit Rubber Gasket for Rear part / front part of YCF air box	Kit Joint pour Boitie avant / Boitie arriere pour boite a air YCF	1	SP113-16/SP213-16/SP313-16
26	GB62-M6x30-W	Butterfly screw M6x30	vis M6x30	1	P12516/P15016/SP113-16/SP213-16/SP313-16/SM15016
<b>Foot Peg assy</b>					

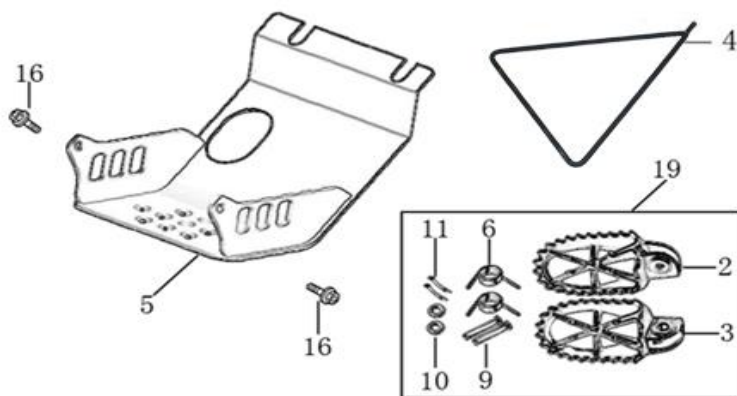

N	Ref.	Description	Français	Qty/ Bike	MODEL
2	YC110-0902-02	Right foot peg Inox Large	Repose pied Inox droit Large	1	SP113-16/SP213-16/SP313-16
3	YC110-0903-02	Left foot peg Inox Large	Repose pied Inox gauche Large	1	SP113-16/SP213-16/SP313-16
4	YC110-190-01	Side stand SP 2015	Triangle support SP 2015	1	SP11516/SP21516/SP31516
5	YC110-207-05	YCF2014 Engine skid plate Steel SPIII	NEW SABOT ACIER FACTORY SPIII	1	SP314-16
6	YC110-0906	Spring for inox foot peg (left/right) $\Phi 2 \times \Phi 16 \times 35 \text{MM}$	ressort repose pied (droit/gauche) inox $\Phi 2 \times \Phi 16 \times 35 \text{MM}$	2	SP113-16/SP213-16/SP313-16
9	119.1-085047	shaft pin for inox footpegs $\phi 8 \times 47.5$	axe repose pied inox $\phi 8 \times 47.5$	2	SP113-16/SP213-16/SP313-16
10	GB97- $\Phi 8$ -W	flat washer $\phi 8 \times 16 \times 1$	rondelle $\phi 8 \times 16 \times 1$	2	ALL BIKES2011-16
11	GB91- $\Phi 2 \times 25$ -W	Cotter pin 2.0x25	goupille 2.0x25	2	ALL BIKES2013-16
16	GB5787-M6x16-W	screw M6X16 for skid plate	vis sabot M6X16	2	ALL BIKES2012-2016
19	YC110-0902/05	Inox foot pegs set Large	Jeu repose pied inox Large	1	SP113-16/SP213-16/SP313-16
<b>Swing Arm assy</b>					

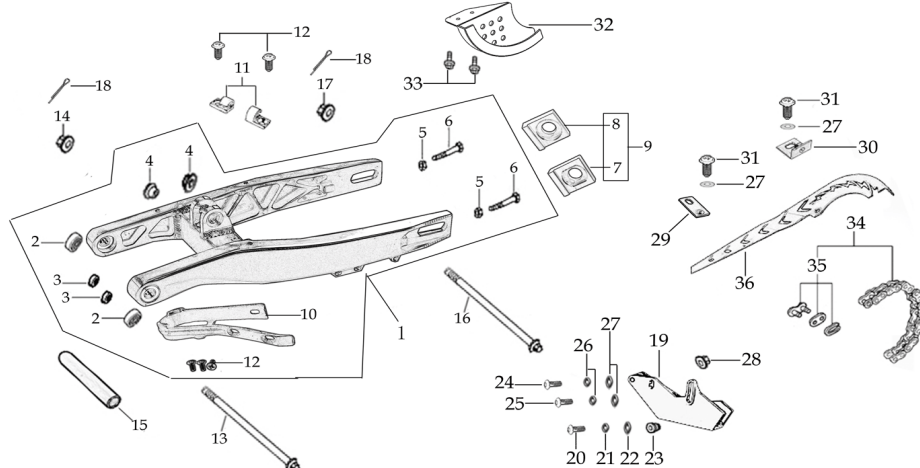

N	Ref.	Description	Français	Qty/ Bike	MODEL
1	YC110-10015	Mono swing arm YCF Aluminium 420mm 2014	bras oscillant mono YCF Aluminium 420mm 2014	1	SP11415/SP214-16/SP314-16
2	6200/28-12	Swing arm bearing $\phi 28 \times \phi 12 \times 8 \text{mm}$	roulement bras oscillant $\phi 28 \times \phi 12 \times 8 \text{mm}$	2	ALL BIKES2009-16
3	YC110-1001-0102	Sleeve for swing arm $\Phi 26.5 \times \Phi 12.5 \times 11 \times 9$	entretoise bras oscillant/amorto $\Phi 26.5 \times \Phi 12.5 \times 11 \times 9$	2	SP112-15/SP212-16/SP312-16
4	YC110-1001-021	Sleeve for swing arm $\phi 12 \times \phi 16 \times \phi 24 \times 10$	entretoise bras oscillant/amorto $\phi 12 \times \phi 16 \times \phi 24 \times 10$	2	SP112-15/SP212-16/SP312-16
5	GB5783-M8x40-W	Exterior hex. Bolt M8X40	vis tendeur chaine M8x40	2	ALL BIKES2012-16 (BUT50A)
6	FB6170-M8-W	Hex. Nut M8	ecrou tendeur chaine M8	2	ALL BIKES2012-16(BUT50A)
7	YC110-11-094-SI	Block axle left SPI/SPII/SPIII SILVER	Tendeur chaine gauche SPI/SPII/SPIII SILVER	1	SP11415/SP214-16/SP314-16
8	YC110-11-093-SI	Block axle right SPI/SPII/SPIII SILVER	Tendeur chaine droit SPI/SPII/SPIII SILVER	1	SP11415/SP214-16/SP314-16
9	YC110-11-095-SI	Set of Block axle SPI/SPII/SPIII SILVER	Jeu tendeur chaine SPI/SPII/SPIII SILVER	1	SP114-15/SP214-16/SP314-16
10	YC110-10-025	Chain slider YCF Aluminium swing arm 420mm PU	patin chaine YCF long pour Bras oscillent Aluminium YCF 420mm PU	1	P1251516/P1501516/SP112-16/SP212-16/SP312-16/SM1501516
11	YC110-10-014-WH	Rear brake clip for WHITE	attache durite frein arriere BLANC	1	SP112-15/SP212-16/SP312-16
12	GB819-M6x12-W	Plus screw M6X12	vis m6x12	5	ALL BIKES2012-14/SP115/SP21516/S P31516
13	YC110-10-033	Swing arm shaft L=236mm	axe bras oscillant $\phi 3$ L=236mm	1	SP113-16/SP213-16/SP313-16

14	GB6187-M12-W	Self locking nut M12	ecrou bras oscillant M12	1	ALL BIKES2012-2016(BUT50A)
15	YC110-1023	Central spacer swing arm CP/FP 2012 Aluminium	Entretoise centrale de bras oscillent YCF CP/FP 2012	1	SP112-15/SP212-16/SP312-16
16	YC110-11-075	Rear wheel axle L=230mm with Self locking nut M14	axe roue arriere L=230mm avec ecrou M14	1	SP112-15/SP212-16/SP312-16
17	GB6187-M14-W	Self locking nut M14	ecrou axe roue arriere M14	1	ALL BIKES2012-16(BUT50A)
18	GB91-Φ2×35-W	Slipt Pin Φ2x35mm	goupille Φ2x35mm	2	SP113-16/SP213-16/SP313-16
19	YC110-1004	YCF chain guide assy for High class range BLACK	guide chaine YCF pour haut de gamme NOIR	1	P1251516/P1501516/SP112-16/SP212-16/SP312-16/SM1501516
20	GB70.2-M5×16	Plus screw M5X16	vis M5X16	1	P1251516/P1501516/SP112-16/SP212-16/SP312-16/SM1501516
21	GB93-Φ5-W	Standard spring washer φ5	rondelle φ5	1	P1251516/P1501516/SP112-16/SP212-16/SP312-16/SM1501516
22	GB97-Φ5-W	Flat washer φ5	rondelle φ5	1	P1251516/P1501516/SP112-16/SP212-16/SP312-16/SM1501516
23	GB6100-M5-CW	Adj. nut for YCF chain guide Φ5×Φ7×Φ10×13mm	Vis réglage guide chaine YCF Φ5×Φ7×Φ10×13mm	1	P1251516/P1501516/SP112-16/SP212-16/SP312-16/SM1501516
24	GB70-M6×20	Stud screw M6X20	vis M6X20	1	P1251516/P1501516/SP112-16/SP212-16/SP312-16/SM1501516
25	GB70-M6×25	Stud screw M6X25	vis M6X25	1	P1251516/P1501516/SP112-16/SP212-16/SP312-16/SM1501516
26	GB93-Φ6-W	Standard spring washer φ6	rondelle φ6	2	P1251516/P1501516/SP112-16/SP212-16/SP312-16/SM1501516
27	GB97-Φ6-W	Flat washer φ6	rondelle φ6	2	P1251516/P1501516/SP112-16/SP212-16/SP312-16/SM1501516
28	GB6177-M6-W	Hex. Nut M6	ecrou tendeur chaine M6	1	P1251516/P1501516/SP112-16/SP212-16/SP312-16/SM1501516
29	YC110-0600-02	Chain box protection support	Support Protection chaine plastique	1	ALL BIKES2012-2016(BUT50A)
30	YC110-0600-021	Chain box protection support	Support Protection chaine plastique	1	ALL BIKES2012-2016(BUT50A)
31	GB818-M6×12-W	Plus screw M6x12	vis M6x12	3	ALL BIKES2012-16(BUT50A)
27	GB97-Φ6	Flat washer φ6	rondelle φ6	3	ALL BIKES2012-16
32	YC110-1010	YCF rear disk protection BLACK	protection disk arriere YCF NOIR	1	SP112-16/SP212-16/SP312-16
33	GB5787-M6×12-W	Plus screw M6X12	vis M6X12	2	SP112-16/SP212-16/SP312-16

34	420DX-108T-X	Chain 420DX-108T extra strong	Chaîne420 108 maillons renforcee	1	SP113-16/SP212-16/SP312-16
35	AR-420	Chain link	Attache rapide chaine	1	All BIKES
36	YC110-0600-01	Chain box protection	Protection chaine plastique	1	ALL BIKES2012-2015(BUT50A)/ALL BIKES2016(BUT50A/F88s/F88se)

**Rear Wheel Assy**

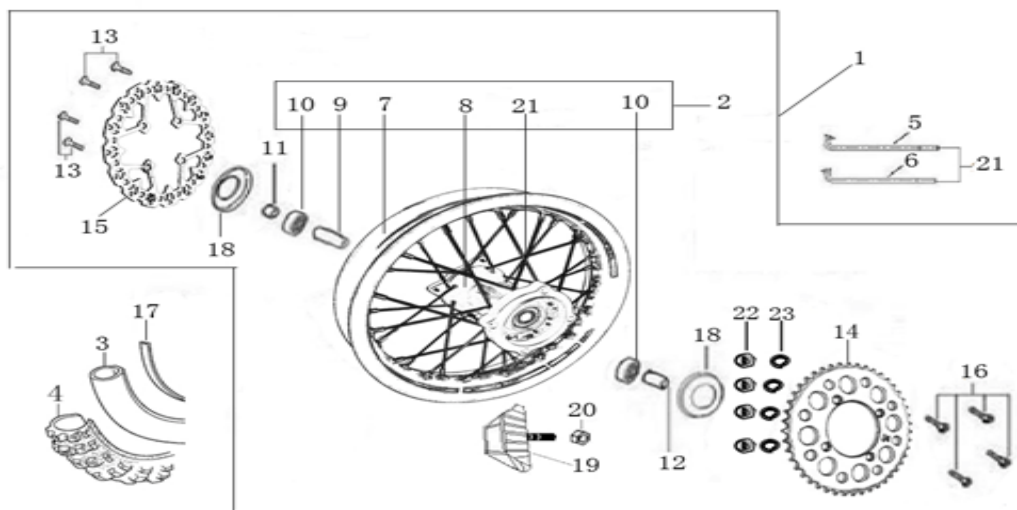

N	Ref.	Description	Français	Qty/ Bike	MODEL
1	YC110-1101-2E-BK	Complete ALUMINIUM Rear wheel 1.85-12' with disk CNC BLACK hub BLACK Rim	roue arriere complète ALUMINIUM 1.85-12 avec disque moyeux cnc NOIR / Jante NOIRE	1	SP316
2	YC110-1102-2E-BK	Complete ALUMINIUM Rear wheel 1.85-12 without disk. CNC hub BLACK / BLACK Rim 2016	roue arriere complète ALUMINIUM 1.85-12 sans disque moyeux CNC NOIR / Jante NOIRE 2016	1	SP316
3	CHAMBRE12	Tube for Rear tire 3.00-12' GL	chambre air 12' standard GL	1	ALL BIKES2012-2016(BUT50A/F88s/F88se/P88s)
	FB6170-M8-Cr	Tire valve nut M8	Ecrou M8 pour chambre a air	1	ALL BIKES
4	80/100/12ARRO	Rear tyre 80/100/12 ARRO 2015	Pneu arriere 80/100/12 ARRO 2015	1	SP216/SP316
7	YC110-1101-01BK	ALUMINIUM 7116 Rim 1.85x12' Black	cerceau roue 1,85x12' ALUMINIUM 7116 Noir	1	SP212-16/SP312-16
8	YC110-1122-05-BK	YCF Rear hub CNC BLACK 2016	Moyeux arrière CNC 2016 NOIR	1	SP316
9	YC110-1109-07	Rear hub axle bushing $\phi 17 \times \Phi 25 \times 67$	entretoise intérieur moyeux arrière $\phi 17 \times \Phi 25 \times 67$	1	SP216/SP316

10	96140-6003-2Z	Ball bearing 6003 Φ35Φ17×10	roulement roue 6003 Φ35Φ17×10	3	SP216/SP316
11	YC110-11-047	Rear wheel spacer right φ15×φ22×43 with step	entretoise roue arriere droite φ15×φ22×43	1	SP216/SP316
12	YC110-11-057	Rear wheel spacer left φ15×φ22×63mm with step	entretoise roue arriere gauche φ15×φ22×63mm	1	SP216/SP316
13	GB70.2-M8×16	Screw for disk M8X16	vis disque frein M8X16	4	ALL BIKES2016 (BUT50A)
14	YC110-11-062/45	YCF Driven sprocket 420-45T 5 holes 2016	couronne acier 45T YCF 5 TROUS	1	SP116/SP216/SP316
15	YC110-1115-01	Rear Brake disc φ200mm 2016	Disque frein arriere φ200 mm 2016	1	ALL BIKES 2016(BUT50A)
16	BT08-M8×30-W	Exterior Hex.Bolt M8×30	vis couronne M8×30	4	SP116/SP216/SP316
17	YC110-11-01	tire lining 12"	fond jante 12'	1	ALL BIKES 2016(BUT50A/F88s/F88se)
18	YC110-0611	oil seal Φ22×Φ35×5	joint spy roue Φ22×Φ35×5	2	ALL BIKES2013-16(BUT50A)
19	GRIPSTER1.85	GRIPSTER 1.85	gripster 1.85	1	SP112-16/SP212-16/SP312-16
20	GB6170-M8-W	Nut M8	ecrou M8	1	SP112-16/SP212-16/SP312-16
21	JR12-13.5	set of spoke 12' (125mm×32)	jeu rayon arriere 12' (125mm×32)	1	SP213-16/SP313-16/SM13-16

REAR BRAKE

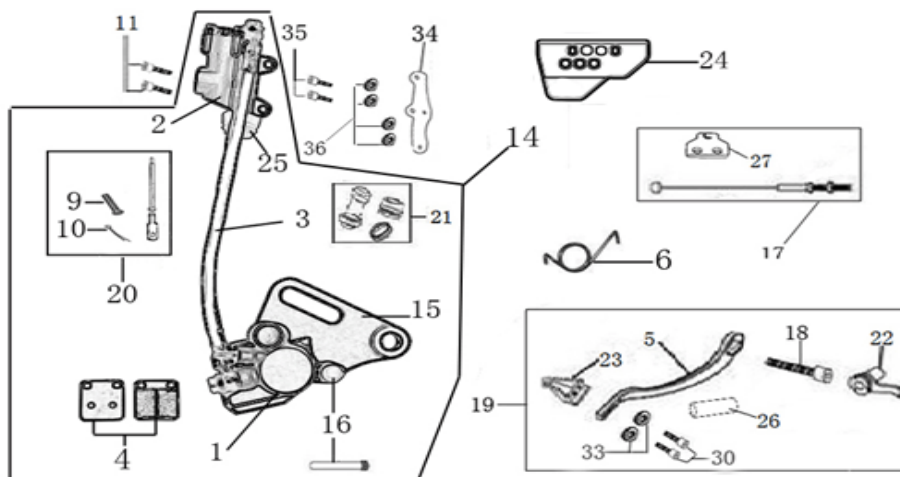

N	Ref.	Description	Français	Qty/ Bike	MODEL
---	------	-------------	----------	--------------	-------



1	YC110-1201-07	Rear Caliper 1 pistons $\Phi 10$ 2016	étrier frein arrière 1 piston $\Phi 10$ 2016	1	SP216/SP316
2	YC110-1201025	Rear reservoir $\phi$ 10mm (with stick L=53mm)	maitre cylindre frein arrière avec embout durite $\phi$ 10mm	1	SP116/SP216/SP316
3	YC110-1201050	Oil steel tube L=465mm $\Phi 10/\Phi 10$ SP2/SP3 2016 oil connection 85°	durite frein arrière L=465mm $\Phi 10/\Phi 10$ SP2/SP3 2016	1	SP216/SP316
4	YC110-1204-02	Friction pad for 1 piston brake w/t abestos with copper substrate 2016	plaquette frein arrière 1 piston SANS AMIANTE 2016	2	SP216/SP316
5	YC110-1205-05	Aluminium brake pedal + 3 cm CP/FP12 / SPI / SPII / SPIII	Pédale de frein + 3 cm Aluminium CP/FP12 / SPI / SPII / SPIII	1	SP113-16/SP213-16/SP313-16
6	YC110-21-06	Spring for Steel brake pedal' SPII/SPIII 2015	ressort pour pédale de frein Acier SPII/SPIII 2015	1	SP11516/SP21516/SP31516
7	FB20-10x14x2-W	Flat washer $\Phi 10 \times \Phi 13.5 \times 2$	rondelle $\Phi 10 \times \Phi 13.5 \times 2$	1	SP11516/SP21516/SP31516
9	119.1-07016	Pin shaft 7x16mm	axe 7x16mm	1	ALL BIKES2012-16 (BUT50A)
10	GB91- $\Phi 1.6 \times 16$ -W	Split pin 1.6x16mm	goupille 1.6x16mm	1	ALL BIKES2012-16 (BUT50A)
11	GB70-M6x20	Hex. Bolt M6x20	vis M6x20	2	ALL BIKES2013-16(BUT50A)
14	YC110-12012-26	Rear brake aasy 1 piston $\Phi 10/\Phi 10$ L=465mm SP2/SP3 2016	Kit frein arriere 1 piston avec gaine plastic $\Phi 10/\Phi 10$ L=465mm SP2/SP3 2016	1	SP216/SP316
15	YC110-1201-09	Rear brake bracket 2016	patte fixation étrier frein arriere 2016	1	SP216/SP316
16	YC110-0555	Rear Brake pads Screw L=50mm Army green	Vis plaquette AR L=50mm	2	SP216/SP316
18	GB70.1-M10x35-W	Nut for brake pedal M10X35	vis pour pédale frein M10X35	1	P88s13-16/P12513-16/P15013-16/SM15013-16/SP113-16/SP213-16/SP313-16
19	YC110-219-01	complete brake pedal SP 2015	Pedale de frein complete SP 2015	1	SP11516/SP21516/SP31516
21	YC110-120111	rubber for rear caliper SP2/SP3 2016	jeu de caoutgouc d'etrier frein arriere SP2/SP3 2016	1	SP216/SP316
22	YC110-1222-01	Brake pedal fixation for Aluminium pedal SPII/SPIII 2015 BLACK	Cylindre pédale de frein Aluminium "externe" SPII/SPIII 2015 NOIR avec roulements	1	SP11516/SP21516/SP31516
	6900Z	Ball bearing 6900Z $\Phi 10 \times \Phi 22 \times 6$ mm	roulement Cylindre pedale 6900Z $\Phi 10 \times \Phi 22 \times 6$ mm	2	SP11516/SP21516/SP31516

	FB13-10×14×6	bushing 10×14×6MM	entretoise 10×14×6MM	1	SP11516/SP21516/SP31516
23	YC110-21-11	Aluminium brake pedal end cap	embout pédale de frein Aluminium	1	SP112-16/SP212-16/SP312-16
25	YC110-12025-01	Rubber for REAR RESERVOIR PUSH STICK 2016	Caoutchouc tige maitre cylindre frein arrier 2016	1	P12516/P15016/SP116/SP216/SP316/SM15016
30	GB70-M6×25	Hex. Bolt M6×25	vis M6×25	2	SP112-16/SP212-16/SP312-16
33	GB93-Φ6-W	Standard spring washer φ6	rondelle φ6	2	SP112-16/SP212-16/SP312-16
34	YC110-1215-03	Mount for rear break reservoir "extern"PILOT/SP 2016	fixation maitre cylindre frein arriere "externe" PILOT/SP 2016	1	P12516/P15016/SM15016/SP116/SP216/SP316
35	GB70-M6×16	Hex. Bolt M6×16	vis M6×16	2	P88s13-15/P12513-16/P15013-16/SM15013-16/SP113-16/SP213-16/SP313-16
36	GB93-Φ6	Standard spring washer φ6	rondelle φ6	4	SP113-16/SP213-16/SP313-16

#### Exhaust system

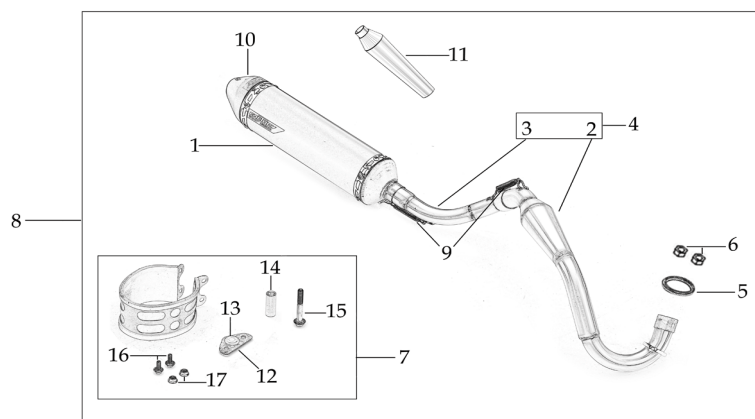

N	Ref.	Description	Français	Qty/ Bike	MODEL
1	YC110-13014-02	YCF Muffler SP2/SP3 (2 springs) 2015	silencieux YCF SP2/SP3 2015	1	SP21516/SP31516
1	YC110-13014-03-BK	Muffler RACING 2016 (2 springs)	silencieux YCF SP3 RACING 2016	1	SP316
2	YC110-1302-13	Racing Exhaust pipe head for competition	Collecteur Racing	1	SP316
3	YC110-1302-15	Racing Exhaust pipe tail for competition (single)	Collecteur Racing Partie Silencierux	1	SP316
4	YC110-13028-01	Racing Exhaust pipe Complete	Collecteur Racing Complet	1	SP316
5	18291/152FMH	Exhaust pipe washer φ32×φ25.5×4	joint pot φ32×φ25.5×4	1	ALL BIKES2012-2016 (BUT50A)

6	GB6170-M6-W	Hex flanged self locking nut M6	écrou M6	2	ALL BIKES
7	YC110-1307-03	Hoop for muffler YCF SPII/SPIII 2015 (with FB13-8×14×35-W 1EA+GB5787-M8×60-W 1EA)	Attache silencieux YCF SPII/SPIII 2015 (DROIT)	1	SP216/SP316
12	YC110-1328-02	Support of muffler hoop 2016		1	SP216/SP316
13	YC110-1404-01	Rubber plug Hoop for muffler Φ8.2Φ20.2×9mm BLACK		1	SP21516/SP31516
14	FB13-8×14×35-W	Muffler Hoop spacer φ8×φ14×35mm	Entretoise attache silencieux φ8×φ14×35mm	1	SP216/SP316
15	GB5787-M8×60-W	Hex. Bolt with flanged M8x60	vis M8x60	1	SP216/SP316
16	GB5787-M6×16-W	Hex. Bolt with flanged M6x16	vis M6x16	2	SP216/SP316
17	GB6177-M6-W	Hex. Flanged nut M6	écrou M6	2	SP216/SP316
8	YC110-139-07	Muffler& Exhaust pipe assy YCF SP3 2016	Echappement complet YCF CRD 94db SP3 2016	1	SP316
9	YC110-1310-01	muffler spring Φ2×Φ10×43mm	ressort pot Φ2×Φ10×43mm	3	SP316
10	YC110-13-35	Muffler end cap SPII 2015	Emout silencieux SPII 2015	1	SP21516/SP31516
11	YC110-13-303	Noise reducer SP2/SP3 2015	Bride de pot YCF SP2/SP3 2015	1	SP21516/SP31516
11	YC110-13-304	Noise reducer SP3 2016	Bride de pot YCF SP3 2016	1	SP316

Seat & Plastic kit

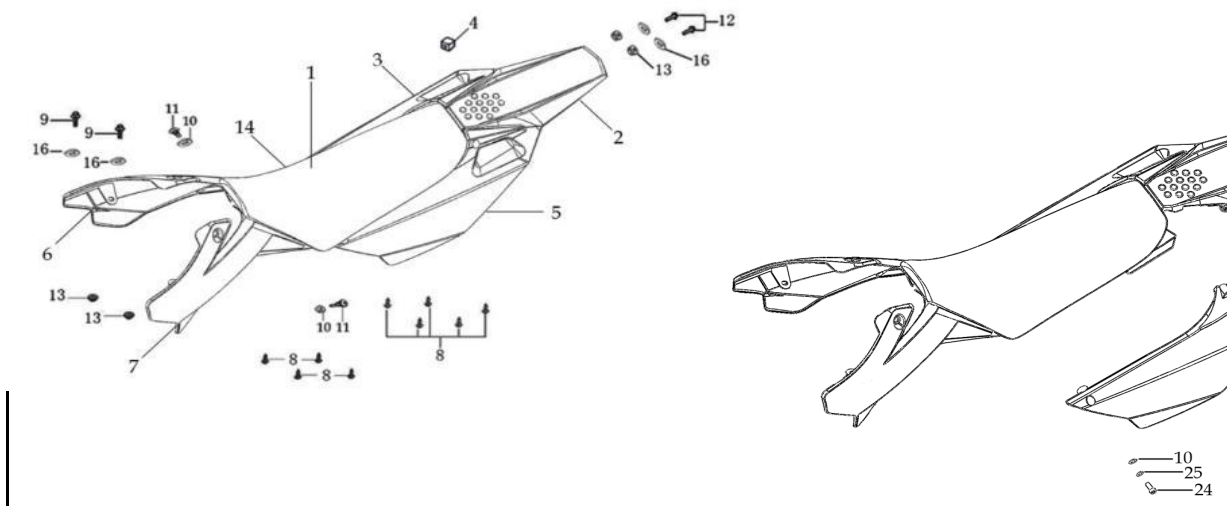

N	Ref.	Description	Français	Qty/ Bike	MODEL
1	YC110-1401-09	YCF Seat assy L=510mm 2016	Sells SP 2016	1	P12516/P15016/SM15016/SP116/SP216/SP316
2	YC110-14-018BK	YCF Rear fender 2016 BLACK	Garde boue arrière YCF 2016 avec Picots NOIR	1	P12516/P15016/SM15016/SP116/SP216/SP316
3	YC110-14-028BK	YCF right side plastic assy 2016 BLACK	Plaque latérale droite YCF 2016 NOIRE	1	P12516/P15016/SM15016/SP116/SP216/SP316
17	YC110-1428-01BK	YCF Handle for right side plastic 2016 BLACK	Paire de Poignees Droite pour Plaque Laterales YCF 2016	1	P12516/P15016/SM15016/SP116/SP216/SP316
19	YC110-1419-01-BK	YCF right side plastic 2016 BLACK	Plaque latérale droite YCF 2016 NOIRE	1	P12516/P15016/SM15016/SP116/SP216/SP316
5	YC110-14-048BK	YCF left side plastic assy 2016 BLACK	Plaque laterale gauche YCF 2016 NOIR	1	P12516/P15016/SM15016/SP116/SP216/SP316
18	YC110-1429-01BK	YCF Handle for left side plastic 2016 BLACK	Paire de Poignees Gauche pour Plaque Laterales YCF 2016	1	P12516/P15016/SM15016/SP116/SP216/SP316
20	YC110-1420-01-BK	YCF left side plastic 2016 BLACK	Plaque laterale gauche YCF 2016 NOIR	1	P12516/P15016/SM15016/SP116/SP216/SP316
21	YC110-1404-01	Cushion for side plastic $\Phi 8.2 \times \Phi 20.2 \times 9$ mm 2016	caoutchouc plaque laterale $\Phi 8.2 \times \Phi 20.2 \times 9$ mm 2016	2	P12516/P15016/SM15016/SP116/SP216/SP316
4	YC110-14-03	Cushion for right side plastic	caoutchouc plaque laterale droite	1	ALL BIKES
22	GB70.2-M5x12-Cr	Plus screw M5X12	vis M5X12	2	P12516/P15016/SM15016/SP116/SP216/SP316
23	GB70-M6x12-Cr	Hex. Bolt M6x12	vis M6x12	2	P12516/P15016/SM15016/SP116/SP216/SP316
24	GB70-M6x16-Cr	Hex. Bolt M6x16	vis M6x16	2	P12516/P15016/SM15016/SP116/SP216/SP316
25	GB95- $\Phi 6$ -W	flat washer $\Phi 6.6 \times \Phi 12$	rondelle $\Phi 6.6 \times \Phi 12$	4	P12516/P15016/SM15016/SP116/SP216/SP316
10	YC110-02-13	Rubber washer $\Phi 6 \times \Phi 14 \times 3$ mm	joint caoutchouc $\Phi 6 \times \Phi 14 \times 3$ mm	4	ALL BIKES2012-16
6	YC110-14-052BK	YCF Right shroud BLACK	Ouie radiateur droite YCF NOIRE	1	ALL BIKES2015-16(BUT50A/50E)
7	YC110-14-062BK	YCF Left side shroud BLACK	Ouie radiateur gauche YCF NOIRE	1	ALL BIKES2015-16(BUT50A/50E)
8	GB845-ST4.8x16-G	Screw for plastic kit ST4.8x16	vis plastique ST4.8x16	8	ALL BIKES2012-16
8	GB845-ST4.8x20-G	Screw for plastic kit ST4.8x20	vis plastique ST4.8x20	1	P88s13-15/P12513-16/P15013-16/SM15013-16/SP113-16/SP213-16/SP313-16
9	GB5787-M6x20-W	hex. Bolt with flanged M6x20	vis M6x20	2	ALL BIKES2012-16
10	YC110-02-13	Rubber washer $\Phi 6 \times \Phi 14 \times 3$ mm	joint caoutchouc $\Phi 6 \times \Phi 14 \times 3$ mm	2	ALL BIKES2012-16

11	FB5787-M5×12-W	hex. Bolt with flanged M5×12	vis M5x12	2	ALL BIKES2012-16
11	GB96-Φ5-W	flat washer Φ5×Φ12	rondelle Φ5×Φ12	2	ALL BIKES2015-16
12	GB5787-M6×20-B	hex. Bolt with flanged M6x20 BLACK	vis M6x20 NOIR	2	ALL BIKES2012-16
13	GB6177-M6-W	Hex. Flanged nut M6	écrou M6	2	ALL BIKES2012-16
14	YC110-14025	YCF seat cover 2016	Housse selle YCF 2016	1	P12516/P15016/SM15016/SP116/SP216/SP316
16	YC110-03-01	Rubber washer Φ6×Φ18×4mm	joint caoutchouc Φ6×Φ18×4mm	4	ALL BIKES2012-16
16	GB96-Φ6	flat washer φ6	rondelle φ6	4	ALL BIKES2012-16

**ELECTRIC**

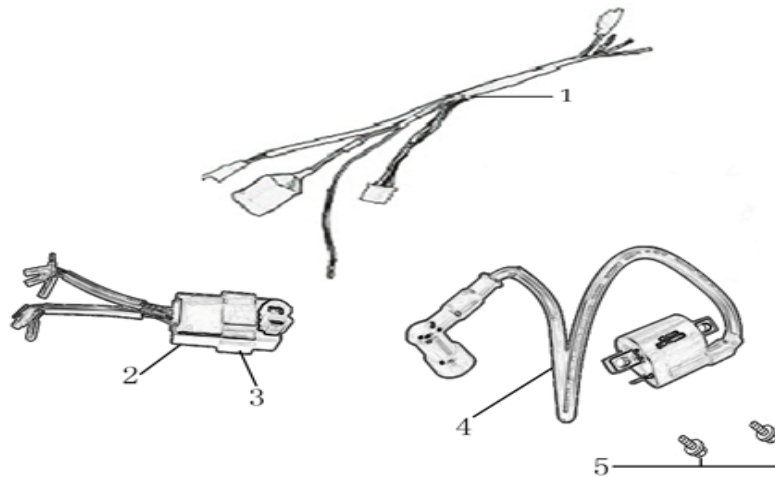

N	Ref.	Description	Français	Qty/ Bike	MODEL
1	86917	WIRE HERNES for ANIMA-FDX	FAISCEAU ELECTRIQUE	1	SP313-16
2	86427	BOX, CDI ANIMA 150	CDI ANIMA 150	1	SP313-16
4	86426	COIL, IGNITION	BOBINE D'ALLUMAGE	1	SP313-16
5	GB5787-M6×16-W	Hex. Bolt M6x16	vis m6x16	2	SP313-16

**Frame**

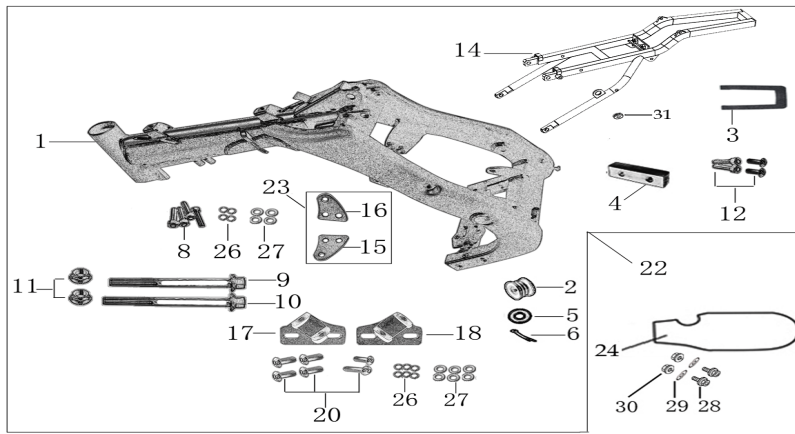

N	Ref.	Description	Français	Qty/ Bike	MODEL
1	YC110-181-05-BK	Chromely frame body SPI / SPII / SPIII 2015 BLACK	Cadre chromolly SPI / SPII / SPIII 2015 NOIR	1	SP11516/SP21516/SP 31516
2	YC110-2201	YCF Chain tensioner component	roulette chaine YCF	1	ALL BIKES2011- 2016 (BUT50A)
3	YC110-0700-12	Tail cover sponge	Mousse Boucle arriere	1	CP12/SP312-16
5	GB97-Φ10-W	Flat washer φ10x17x2	rondelle φ10x17x2	1	ALL BIKES2014- 16 (BUT50A)
6	GB91-Φ2x25-W	cotter pin φ2.0x25	goupille φ2.0x25	1	ALL BIKES2014- 16 (BUT50A)
15	YC110-16-033-BK	frame engine pads left SPI/SPII/SPIII BLACK	patte de cadre gauche SPI/SPII/SPIII NOIRE	1	SP113-16/SP212- 16/SP312-16
16	YC110-16-043-BK	frame engine right left SPI/SPII/SPIII BLACK	patte de cadre droite SPI/SPII/SPIII NOIRE	1	SP113-16/SP212- 16/SP312-16
8	GB70-M8x20	Hex. Bolt with flanger M8x20	vis boucle arriere M8x20	4	P88s13-15/P12513- 16/P15013-16/SP113- 16/SP213-16/SP313- 16/SM15013-16
26	GB93-Φ8-W	washer φ8	rondelle φ8	4	P88s13-15/P12513- 16/P15013-16/SP113- 16/SP213-16/SP313- 16/SM15013-16
27	GB97-Φ8-W	Flat washer Φ8	rondelle Φ8	4	P88s13-15/P12513- 16/P15013-16/SP113- 16/SP213-16/SP313- 16/SM15013-16
9	GB5787-M8x130-W	Hex. Bolt with flanger face M8x130	vis M8x130	1	SP113-16/SP213- 16/SP313-16
9	GB5787-M8x105-W	Hex. Bolt with flanger M8x105	vis M8x105	1	F12513-16/F125s13- 16/F125se1516/SM125s13- 16/SP113-16/SP213- 16/SP313-16
10	GB6187-M8-W	Self locking nut M8	ecrou M8	2	ALL BIKES
14	YC110-1614-06	Aluminium rear frame part SP3 2016 SILVER	Boucle arriere de cadre Aluminium SP3 2016 SILVER	1	SP316

31	YC110-1404-01	Rubber for Subframe	Caoutchouc pour Boucle Arriere	2	P12516/P15016/SM15016/SP116/SP216/SP316
12	GB70-M8×20	Hex. Bolt M8X20	vis M8x20	2	P88s13-15/P12513-16/P15013-16/SP113-16/SP213-16/SP313-16/SM15013-16
12	GB70.2-M8×20	screw M8x20	vis M8x20	2	SP113-16/SP213-16/SP313-16
17	YC110-16-051-BK	foot pegs support left SPI/SPII/SPIII BLACK	support repose pied gauche SPI/SPII/SPIII NOIR	1	SP113-16/SP212-16/SP312-16
18	YC110-16-055-BK	foot pegs support right SPI/SPII/SPIII BLACK	support repose pied droite SPI/SPII/SPIII NOIR	1	SP113-16/SP212-16/SP312-16
20	GB70.2-M8×25	screw M8x25	vis M8x25	4	SP114-16/SP214-16/SP314-16
20	GB70.2-M8×50-Cr	screw M8x50	vis M8x50	1	SP113-16/SP213-16/SP313-16
20	GB70.2-M8×25-Cr	screw M8x25	vis M8x25	1	SP113-16/SP213-16/SP313-16
26	GB93-Φ8-W	washer φ8	rondelle φ8	6	P88s13-15/P12513-16/P15013-16/SP113-16/SP213-16/SP313-16/SM15013-16
27	GB97-Φ8-W	Flat washer Φ8	rondelle Φ8	6	P88s13-15/P12513-16/P15013-16/SP113-16/SP213-16/SP313-16/SM15013-16
21	YC110-170-03-BK	complète frame SP3 BLACK 2016	cadre complet SP3 2016 NOIR	1	SP316
22	YC110-16-066-BK	set of engine pads Black SPI/SPII/SPIII ( with GB97-Φ8-W 4EA+GB70-M8×20 4EA+GB93-Φ8-W 4EA )	jeu de patte de cadre Noir SPI/SPII/SPIII	1	SP113-16/SP212-16/SP312-16
24	YC110-0460-01	Rear shock absorber rubber protection 2016	Bavette caoutchouc 2016	1	SP116/SP216/SP316
28	GB5787-M6×30-W	Hex. Bolt M6×30	vis M6×30	2	SP113-16/SP213-16/SP313-16
29	GB96-Φ6-W	Washer φ6×φ18mm	Rondelle φ6×φ18mm	2	SP113-16/SP213-16/SP313-16
30	GB6187-M6-W	Self-locking Nut M6	écrou M6	2	SP113-16/SP213-16/SP313-16

GRAPHICS

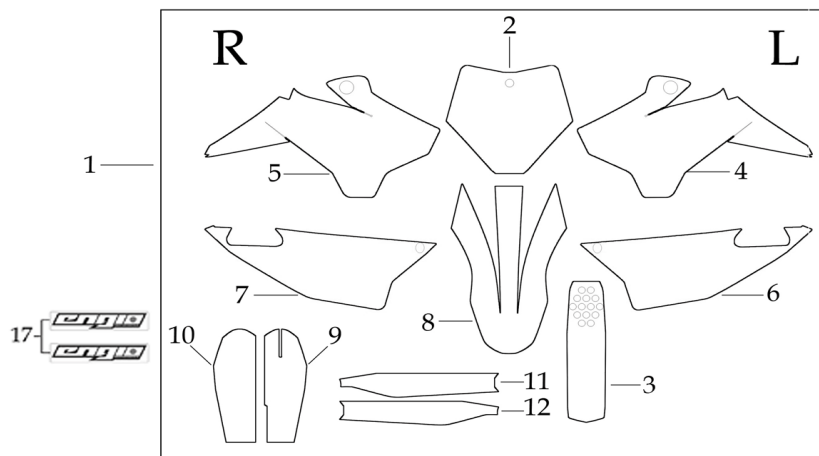

N	Ref.	Description	Français	Qty/ Bike	MODEL
1	KDSP31902016	Complete graphic kit SP3190 2016	Kit deco complet SP3190 2016	1	SP319016
2	YC110-33-0111	Front plate graphic SP3190 2016	Sticker Plaque avant SP3190 2016	1	SP319016
3	YC110-33-0211	Rear mudguard graphic SP3190 2016	Sticker GB Arriere SP3190 2016	1	SP319016
4	YC110-33-0311	Left shrouder graphic SP3190 2016	Sticker Ouie gauche radiateur SP3190 2016	1	SP319016
5	YC110-33-0411	Right shrouder graphic SP3190 2016	Sticker Ouie droite radiateur SP3190 2016	1	SP319016
6	YC110-33-0511	Left side plate graphic SP3190 2016	Sticker Plaque laterales gauche SP3190 2016	1	SP319016
7	YC110-33-0611	Right side plate graphic SP3190 2016	Sticker Plaque laterales droite SP3190 2016	1	SP319016
8	YC110-33-078	Front fender Front fender graphic SP 2016	Sticker GB Avant SP 2016	1	SP116/SP216/SP3 16
9	YC110-33-0811	Front left shock protection graphic SM150/SP3190 2016	Sticker Protection gauche fourche SM150/SP3190 2016	1	SM15016/SP31901 6/
10	YC110-33-0911	Front right shock protection graphic SM150/SP3190 2016	Sticker Protection droit fourche SM150/SP3190 2016	1	SM15016/SP31901 6/
11	YC110-33-1010	Left swing arm protection graphic SP3 2016	Sticker Protection gauche bras oscillent SP3 2016	1	SP316
12	YC110-33-1110	Right swing arm protection graphic SP3 2016	Sticker Protection droit bras oscillent SP3 2016	1	SP316
17	KDENG-02	ENGI Front Fork graphic 2016	Sticker Fourche ENGI 2016	2	SP316



	YC110-1910	GAS TANK STICKER	STICKER RESERVOIR	1	ALL BIKES2013-16(BUT50A)
	YC110-1911	Motocross Rims Sticker BLUE	Sticker Jantes Motocross BLEU	4	SP213-16/SP313-16
	YC110-1912	YCF Air box Sticker	Sticker Boite a Air YCF	1	SP113-16/SP213-16/SP313-16
	YC110-1901	Sticker Chain	Autocollant Chaîne	1	ALL BIKES2013-16
	YC110-1902	Sticker Tire	Autocollant Pression Pneu	1	ALL BIKES2013-16
	YC110-1903	Sticker Warning OIL Level	Autocollant Attention Niveau Huile	1	ALL BIKES2013-16
	YC110-1904	Sticker Rear Mudguard 70×57mm	Autocollant garde boue arriere 70×57mm	1	ALL BIKES2013-16
	YC110-1905	Sticker CE	Autocollant CE	1	ALL BIKES2013-16
	YC110-1906	Warning sticker	Sticker Attention	1	ALL BIKES2013-16
	YC110-1907	Warning Sticker Transport	Sticker Caisse Avertissement Transport	1	ALL BIKES2013-16
	YC110-1908	Warning Sticker Shosk Absorber	Sticker Avertissement Amortisseur	1	ALL BIKES2013-16

## ENGINES

	86876	Engine Daytona 190cc 4 Valves	Moteur Daytona 190cc 4 valves ANIMA	1	SP319014-16
	17311-6	INLET PIPE ,Pro ANIMA 150 for PE28	PIPE ADMISSION PE28	1	SP316
	46758	RUBBER MANIFOLD SET (with YC50-0803 1EA+YC110-2029 1EA+GB70-M6×15-B 2EA)	Manchon pipe admission Daytona	1	SP316
	YC110-2030	RUBBER MANIFOLD SET PE28	Manchon pipe admission Daytona PE28	1	SP316
	YC110-2029	YCF carburettor paper gasket	joint papier carburateur	1	SP316
	YC50-0803	Holding ring φ21-φ44mm	collier FILTRE φ21-φ44mm	1	SP316

	GB70-M6×15-B	Hex. Bolt M6x15	vis M6x15	2	SP316
	86373	COVER, MAGNET	CARTER ALLUMAGE ANIMA 150	1	SP313-16
	YC140-27600-SI	STEEL KICK YCF 2015 BIG HOLE	KICK ACIER 2015 GROS DIAMETRE SILVER	1	P1501516/SM1501516/SP11516/SP21516/SP31516
	24700-GY	GEARSHIFT FACTORY LOGO GREY	SELECTEUR YCF GRISE	1	SP316

### CARBU

	85707-1	Carburetor KEIHIN PE28 with main jet 125 and slow jet 42	Carburateur KEIHIN PE28 GICLEUR PRINCIPAL 125 / GICLEUR RALENTI 42	1	SP316
--	---------	--	--	---	-------

### CARTONS - CAISSES MOTOS

	YC110-CARTON-CP	BIKE BOX CLASSIC 1520×380×840mm	CARTON EMBALLAGE MOTO CLASSIC	1	CP12/FP12/P1251516/P1501516/SM1501516/SP11316/SP213-16/SP313-16
	YC110-FOAMBOX	Foam box 420×340×160mm	Cale PS	1	ALL BKIES2014-16
	YC110-FILM	Protective film for seat 600×600×0.02mm	Protection plastique de Selle	1	ALL BKIES2014-16

### CATALOGUES - FICHES MOTOS - FICHES STICKER

	YC110-0700-01	Accessory tools	Trousse a outils	1	ALL BIKES
	YC110-0700-0201	Owner manual 2015	Manuel Utilisation 2015	1	ALL BIKES2013-16
	YC110-0700-0401	Vin Plate 2015	Plaque Vin 2015	1	ALL BIKES2013-16
	YC110-0700-03	A4 sheet assy	Fiche A4	1	ALL BIKES

2016











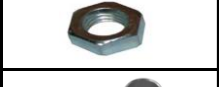



















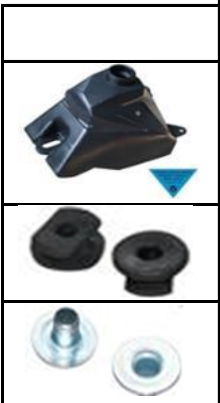

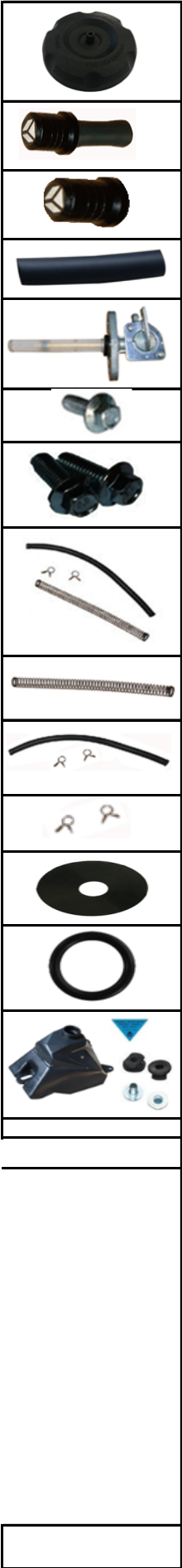

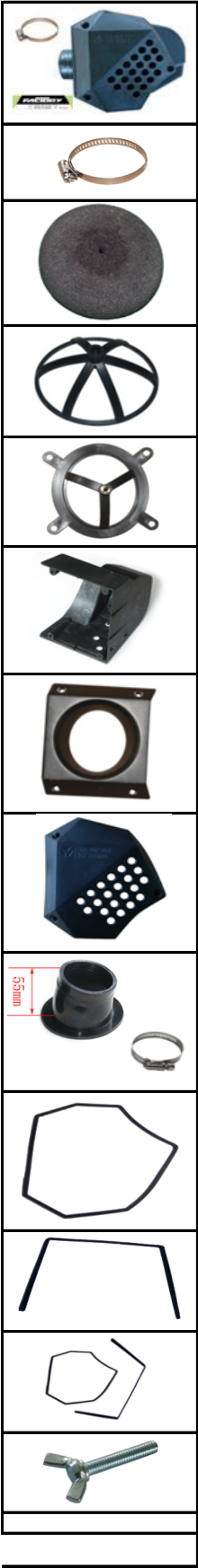

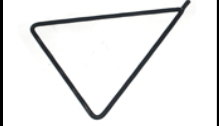
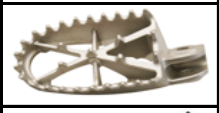











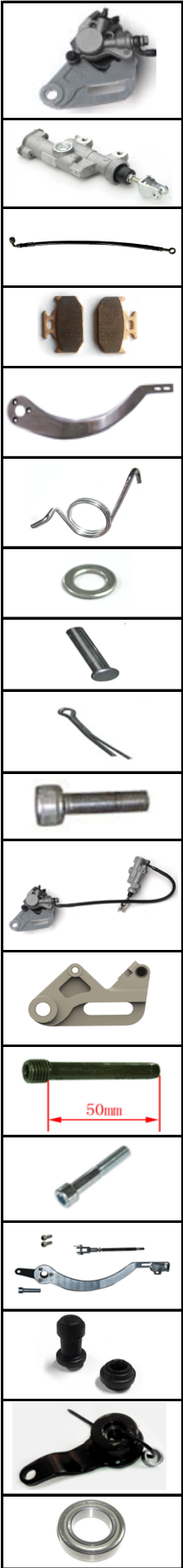



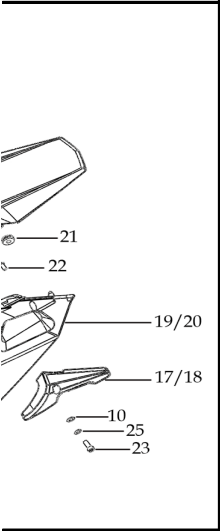



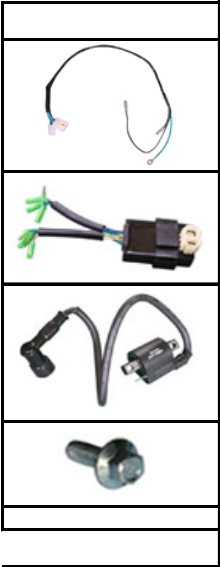











**YAMAHA**  
MOTOCROSS  
compatible 12 & 14 pouces (in)



**DRIVE CHAIN - CHAÎNE**  
KEEP CHAIN ADJUSTED AND LUBRICATED. USE A PRESSURE WASH GUN'S NOZZLE FOR BEST RESULTS. ALWAYS USE THE CORRECT LUBRICANT. ALWAYS USE THE CORRECT LUBRICANT. ALWAYS USE THE CORRECT LUBRICANT.  
YCF FRANCE  
GENÈVE SUISSE

**TIRE INFORMATION - PNEUS**  
COLD TIRE PRESSURE FRONT 30 PSI / 2.0 BAR - REAR 30 PSI / 2.0 BAR  
MAXIMUM WEIGHT CONTACT POINT PRESSURE  
MAX. TIRE PRESSURE FRONT 30 PSI / 2.0 BAR  
MAX. TIRE PRESSURE REAR 30 PSI / 2.0 BAR  
PNEU PRESSION AVANT 2 BAR - ARRIÈRE 2.0 BAR  
PNEU PRESSION AVANT 2.0 BAR - ARRIÈRE 2.0 BAR

**WARNING - IMPORTANT**  
BEFORE OPERATING THIS VEHICLE YOU MUST CHECK THE ENGINE OIL LEVEL.  
AVANT DE DÉMARRER LE VÉHICULE, VÉRIFIER LE NIVEAU D'HUILE MOTEUR.

**WARNING - AVERTISSEMENT**  
ATTENTION: L'ÉLECTRICITÉ EST DANGÉREUSE. NE PAS TOUCHER LES PARTIES MÉTALLIQUES VIVES. NE PAS TOUCHER LES PARTIES MÉTALLIQUES VIVES. NE PAS TOUCHER LES PARTIES MÉTALLIQUES VIVES.  
ATTENTION: L'ÉLECTRICITÉ EST DANGÉREUSE. NE PAS TOUCHER LES PARTIES MÉTALLIQUES VIVES. NE PAS TOUCHER LES PARTIES MÉTALLIQUES VIVES. NE PAS TOUCHER LES PARTIES MÉTALLIQUES VIVES.  
ATTENTION: L'ÉLECTRICITÉ EST DANGÉREUSE. NE PAS TOUCHER LES PARTIES MÉTALLIQUES VIVES. NE PAS TOUCHER LES PARTIES MÉTALLIQUES VIVES. NE PAS TOUCHER LES PARTIES MÉTALLIQUES VIVES.  
YCF



**NE PAS OUBLIER DE FAIRE LES RÉSERVES D'USAGES AUPRÈS DU TRANSPORTEUR À RÉCEPTION DES COLIS SUR LE BORD DE LIVRAISON.**  
**PLEASE CHECK THE CONDITION OF CRATE AT RECEIPT OF GOODS. ANY DAMAGE SHOULD BE NOTED ON THE CONNOTE WITH THE FREIGHT CARRIER.**

**WARNING - AVERTISSEMENT**  
WARNING: THE SHOCK ABSORBER IS NOT LOCKED.  
ATTENTION: LA VIS DE L'AMORTISSEUR N'EST PAS SERRÉE.

